



Powerware® BladeUPS®
12 kVA
User's Guide

Class A EMC Statements

FCC Part 15

NOTE This equipment has been tested and found to comply with the limits for a Class A digital device, pursuant to part 15 of the FCC Rules. These limits are designed to provide reasonable protection against harmful interference when the equipment is operated in a commercial environment. This equipment generates, uses, and can radiate radio frequency energy and, if not installed and used in accordance with the instruction manual, may cause harmful interference to radio communications. Operation of this equipment in a residential area is likely to cause harmful interference in which case the user will be required to correct the interference at his own expense.

ICES-003

This Class A Interference Causing Equipment meets all requirements of the Canadian Interference Causing Equipment Regulations ICES-003.

Cet appareil numérique de la classe A respecte toutes les exigences du Règlement sur le matériel brouilleur du Canada.

EN 62040-2

Some configurations are classified under EN 62040-2 as "Class-A UPS for Unrestricted Sales Distribution." For these configurations, the following applies:

WARNING This is a Class A-UPS Product. In a domestic environment, this product may cause radio interference, in which case, the user may be required to take additional measures.

VCCI Notice

この装置は、情報処理装置等電波障害自主規制協議会（VCCI）の基準に基づくクラスA情報技術装置です。この装置を家庭環境で使用すると電波妨害を引き起こすことがあります。この場合には使用者が適切な対策を講ずるよう要求されることがあります。

Eaton, Powerware, BladeUPS, Powerware Hot Sync, ABM, and X-Slot are registered trademarks and ConnectUPS is a trademark of Eaton Corporation or its subsidiaries and affiliates. Greenlee is a registered trademark of Greenlee Textron. Modbus is a registered trademark of Schneider Electric.

©Copyright 2007 Eaton Corporation, Raleigh, NC, USA. All rights reserved. No part of this document may be reproduced in any way without the express written approval of Eaton Corporation.

Requesting a Declaration of Conformity

Units that are labeled with a CE mark comply with the following harmonized standards and EU directives:

- Harmonized Standards: IEC 61000-3-12
- EU Directives: 73/23/EEC, Council Directive on equipment designed for use within certain voltage limits
93/68/EEC, Amending Directive 73/23/EEC
89/336/EEC, Council Directive relating to electromagnetic compatibility
92/31/EEC, Amending Directive 89/336/EEC relating to EMC

The EC Declaration of Conformity is available upon request for products with a CE mark. For copies of the EC Declaration of Conformity, contact:

Eaton Power Quality Oy
Koskelontie 13
FIN-02920 Espoo
Finland
Phone: +358-9-452 661
Fax: +358-9-452 665 68

Special Symbols

The following are examples of symbols used on the UPS or accessories to alert you to important information:



RISK OF ELECTRIC SHOCK - Indicates that a risk of electric shock is present and the associated warning should be observed.



CAUTION: REFER TO OPERATOR'S MANUAL - Refer to your operator's manual for additional information, such as important operating and maintenance instructions.



This symbol indicates that you should not discard the UPS or the UPS batteries in the trash. This product contains sealed, lead-acid batteries and must be disposed of properly. For more information, contact your local recycling/reuse or hazardous waste center.



This symbol indicates that you should not discard waste electrical or electronic equipment (WEEE) in the trash. For proper disposal, contact your local recycling/reuse or hazardous waste center.

Table of Contents

- 1 Introduction 1**
- 2 Safety Warnings 5**
- 3 Installation 19**
 - Inspecting the Equipment 19
 - Unpacking the Cabinet 20
 - Parallel System Setup 21
 - Preparing the Rack 22
 - Installing the Input and Output Wiring 24
 - EBM Setup 28
 - Checking the EBM Accessories 28
 - Rack Setup for the EBM 29
 - UPS Setup 34
 - Checking the UPS Accessories 34
 - Rack Setup for the UPS 35
 - Installing the UPS Internal Batteries 42
 - EBM Installation 44
 - Standalone UPS Installation 48
 - Parallel UPS Installation 50
 - Multiple Parallel UPS Installation 50
 - Single Parallel-Ready UPS Installation 56
 - UPS Installation into an Existing Parallel System 60
 - Standalone UPS Initial Startup 66
 - Parallel System Initial Startup 68
- 4 Operation 71**
 - Control Panel Functions 71
 - Changing the Language 72
 - Display Functions 72
 - User Settings 74
 - Operating Modes 76
 - Normal Mode 76
 - Battery Mode 77
 - Bypass Mode 77
 - Standby Mode 77

TABLE OF CONTENTS

UPS Startup and Shutdown	78
Starting a Standalone UPS	78
Starting a Parallel System	80
Starting the UPS on Internal Bypass	81
Standalone UPS Shutdown	83
Individual Paralleled UPS Shutdown	84
Parallel System Shutdown	85
Transferring the UPS Between Modes	86
Setting Power Strategy	86
Configuring Battery Settings	87
Configuring the UPS for EBMs	87
Running Automatic Battery Tests	87
Setting the Battery Low Alarm Level	88
5 Communication	89
Installing Communication Options and Control Terminals	90
Communication Options	91
DB-9 Communication Port	92
X-Slot Cards	93
Control Terminals	94
Remote Emergency Power-off	95
Relay Output Contacts	96
Programmable Signal Inputs	97
Parallel Communication	98
Mode Transfers	98
Redundant Signal Wiring	98
Auto-Identification	99
Metering	99
6 UPS Maintenance	101
UPS and Battery Care	101
Storing the UPS and Batteries	101
When to Replace Batteries	102
Replacing Batteries	102
How to Replace EBMs	103
How to Replace UPS Internal Batteries	104
Testing New Batteries	108
Replacing the Electronics Module	109
Recycling the Used Battery or UPS	112
Updating the UPS Firmware	112

- 7 Specifications 113**
- 8 Troubleshooting 119**
 - Typical Alarms and Conditions 119
 - Silencing the Alarm 123
 - Service and Support 123
- 9 Warranty 125**
 - One-Year Limited Warranty (Global) 125

Chapter 1 Introduction

The Eaton® Powerware® BladeUPS® uninterruptible power system (UPS) protects your sensitive electronic equipment from the most common power problems including power failures, power sags, power surges, brownouts, and line noise.

Power outages can occur when you least expect it and power quality can be erratic. These power problems have the potential to corrupt critical data, destroy unsaved work sessions, and damage hardware — causing hours of lost productivity and expensive repairs.

With the BladeUPS, you can safely eliminate the effects of power disturbances and guard the integrity of your equipment. The BladeUPS is designed for critical applications such as ultra high-density blade servers in a data center environment. Figure 1 shows the BladeUPS with an optional Extended Battery Module (EBM).

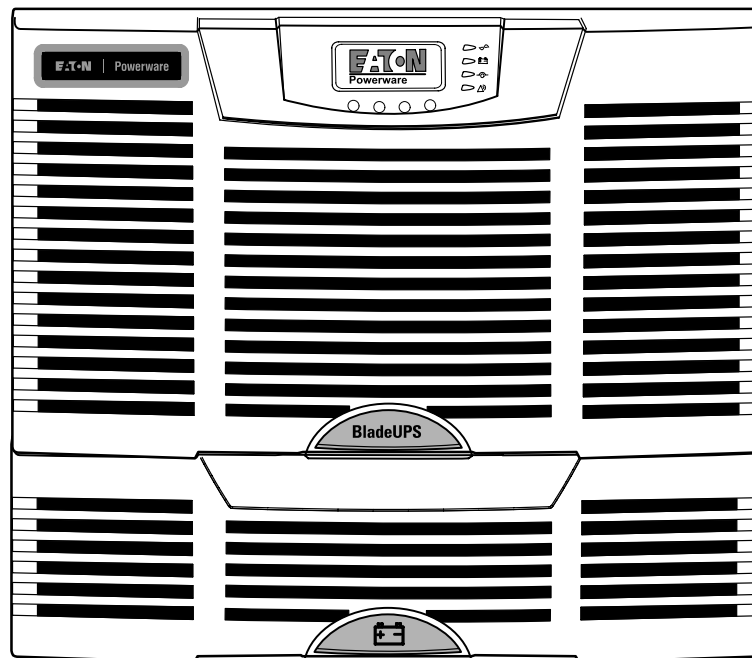

Figure 1. The BladeUPS with Optional EBM

Providing outstanding performance and reliability, the BladeUPS's unique benefits include the following:

- High-density three-phase input, three-phase output UPS.
- Scalable to 60 kW (redundant N+1 configuration) by connecting up to five additional parallel UPS modules. A standalone UPS converts to a parallel UPS by changing the line cord. Each UPS in the parallel system connects to a BladeUPS Bar pre-installed in the rear of a Powerware rack. Racks can be configured for bottom or top entry.
A Powerware Hot Sync® Controller Area Network (CAN) Bridge Card in each paralleled UPS provides connectivity for system metering and operational mode control. In a parallel system not fully loaded, the system will shift load to UPSs with the strongest batteries or additional EBMs to maximize runtime when on battery. Parallel systems can be configured for capacity or redundancy.
- 6U height that fits any standard 48 cm (19") rack.
- Normal operating mode that minimizes heat generation by operating at typically >96.5% efficiency. The UPS filters incoming AC power and provides consistent power to your equipment without draining the battery.
- For utility line input that exceeds normal operating range, automatic transfer to an online, double-conversion, high-frequency UPS design with pure sine wave output and power-factor correction.
- ABM® technology that uses advanced battery management to increase battery service life, optimize recharge time, and provide a warning before the end of useful battery life.
- Extended runtime with up to four EBMs per UPS. An optional 0.9m (3 ft) battery extension cable is available.
- Hot-swappable electronics module and batteries that simplify maintenance by allowing you to replace them safely without powering down the critical load.
- Emergency shutdown control through the remote emergency power-off (REPO) port.
- One standard communication option with a DB-9 serial port.
- Optional X-Slot® cards with enhanced communication capabilities for network connectivity with monitoring and control.
- Firmware that is service upgradable through the DB-9 communication port.
- Backed by worldwide agency approvals.

The BladeUPS Bar for parallel systems, mounted in the rear of a Powerware rack, provides the required input and output connections for the paralleled UPSs and has a single system-rated input connection. Figure 2 shows an example of a BladeUPS parallel system.

The BladeUPS system can be installed with Powerware remote power panels and rack-mounted power distribution systems.

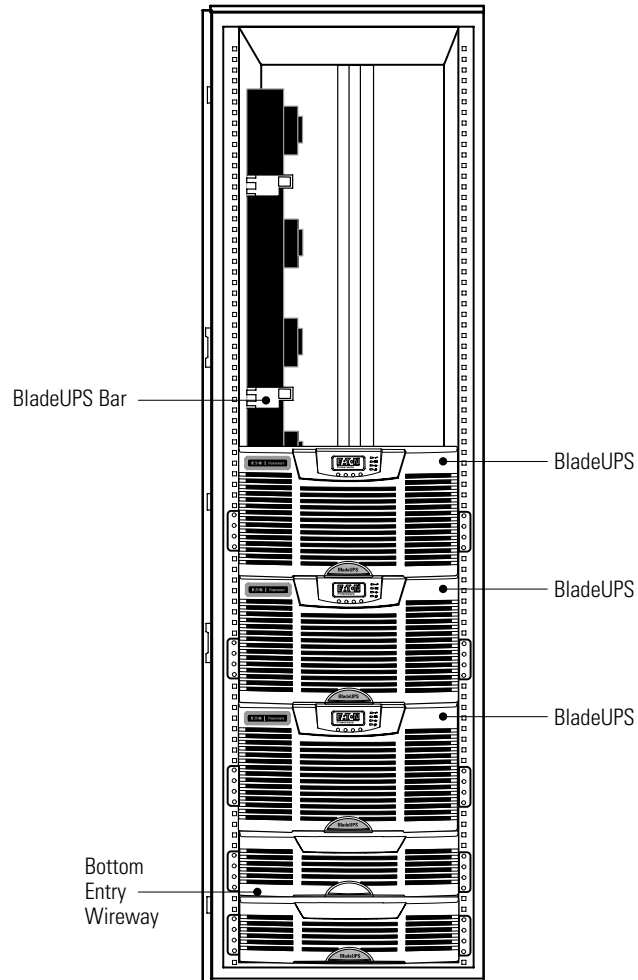

Figure 2. Example of a BladeUPS Parallel System

Note the following guidelines when configuring your BladeUPS standalone unit or parallel system:

- There is a maximum of four EBMs per BladeUPS.
- The EBM(s) for a standalone BladeUPS can be mounted directly below the BladeUPS or, with rack side panels removed, in an adjacent rack to the left of the rack containing the BladeUPS.
- For consistent runtimes, each BladeUPS in a parallel system should have the same number of EBMs.
- Mount EBMs for a parallel system in an adjacent rack to the left of the rack containing the BladeUPSs (rack side panels removed).
- Some load equipment may require phase rotation or phase relationship coordination to ensure proper operation. Review your equipment manufacturer's power requirement documents to ensure your connected equipment operates correctly.

Figure 29 on page 45 shows an example of a standalone UPS with EBMs. Figure 30 on page 46 and Figure 31 on page 47 show examples of a parallel system with EBMs.

Chapter 2 Safety Warnings

IMPORTANT SAFETY INSTRUCTIONS SAVE THESE INSTRUCTIONS

This manual contains important instructions that you should follow during installation and maintenance of the UPS and batteries. Please read all instructions before operating the equipment and save this manual for future reference.

DANGER



This UPS contains **LETHAL VOLTAGES**. All repairs and service should be performed by **AUTHORIZED SERVICE PERSONNEL ONLY**. There are **NO USER SERVICEABLE PARTS** inside the UPS.

WARNING



- This UPS contains its own energy source (batteries). The UPS output may carry live voltage even when the UPS is not connected to an AC supply.
 - To reduce the risk of fire or electric shock, install this UPS in a temperature and humidity controlled, indoor environment, free of conductive contaminants. Ambient temperature must not exceed 40°C (104°F). Do not operate near water or excessive humidity (95% maximum).
 - To reduce the risk of fire, connect only to a circuit provided with branch circuit overcurrent protection in accordance with the National Electrical Code, ANSI/NFPA 70. See page 48 (standalone UPS) or page 21 (parallel system).
 - Output overcurrent protection and disconnect switch must be provided by others.
 - To comply with international standards and wiring regulations, the sum of the leakage current of the UPS and the total equipment connected to the output of this UPS must not have an earth leakage current greater than 3.5 milliamperes.
-



CAUTION

- Batteries can present a risk of electrical shock or burn from high short-circuit current. Observe proper precautions. Servicing should be performed by qualified service personnel knowledgeable of batteries and required precautions. Keep unauthorized personnel away from batteries.
- Proper disposal of batteries is required. Refer to your local codes for disposal requirements.
- Never dispose of batteries in a fire. Batteries may explode when exposed to flame.

Sikkerhedsanvisninger

VIGTIGE SIKKERHEDSANVISNINGER GEM DISSE ANVISNINGER

Denne manual indeholder vigtige instruktioner, som skal følges under installation og vedligeholdelse af UPS'en og batterierne. Læs venligst alle instruktioner inden betjening af udstyret og gem denne manual mhp. fremtidige opslag.



FARE

Denne UPS indeholder LIVSFARLIG HØJSPÆNDING. Alle reparationer og vedligeholdelse bør kun udføres af en AUTORISERET SERVICE TEKNIKER. Ingen af UPS'ens indvendige dele kan repareres af brugeren.



ADVARSEL!

- Denne UPS indeholder sin egen energikilde (batterier). Udgangsstikket på UPS'en kan endog være strømførende, når UPS'en ikke er koblet til en vekselstrømsforsyning.
- Installér denne UPS i et temperatur- og fugtighedskontrolleret indendørs miljø, frit for ledende forureningsstoffer for at formindske risikoen for brand og elektrisk stød. Rumtemperaturen må ikke overstige 40°C. UPS'en bør ikke betjenes nær vand eller høj fugtighed (maksimalt 95%).
- For at reducere risikoen for brand må tilkobling kun ske til et kredsløb forsynet med 100 ampere maks. linieforgrenings overbelastningsbeskyttelse i overensstemmelse med National Electrical Code, ANSI/NFPA 70.
- Udgangsoverbelastningsbeskyttelsen og afbryderkontakten skal leveres af andre.
- I overensstemmelse med internationale normer og bestemmelser for el-installation må det udstyr, der er forbundet til udgangen af denne UPS, tilsammen ikke overskride en jordafdelingsspænding på mere end 3,5 milliamperere.



ADVARSEL

- Batterierne kan give risiko for elektrisk stød eller brandsår forårsaget af høj kortslutningsstrøm. Overhold gældende forsigtighedsregler. Servicing skal udføres af kvalificeret servicepersonale med kendskab til batterier og gældende forsigtighedsregler. Hold uautoriseret personale væk fra batterierne.
- Korrekt bortskaffelse af batterier er påkrævet. Overhold gældende lokale regler for bortskaffelsesprocedurer.
- Skaf dig aldrig af med batterierne ved at brænde dem. Batterierne kan eksplodere ved åben ild.

Belangrijke Veiligheidsinstructies

BELANGRIJKE VEILIGHEIDSINSTRUCTIES BEWAAR DEZE INSTRUCTIES

Deze handleiding bevat belangrijke instructies die u dient te volgen tijdens de installatie en het onderhoud van de UPS en de accu's. Lees alle instructies voordat u de apparatuur in bedrijf neemt en bewaar deze handleiding als naslagwerk.



GEVAAR

Deze UPS bevat LEVENSGEVAARLIJKE ELEKTRISCHE SPANNING. Alle reparaties en onderhoud dienen UITSLUITEND DOOR ERKEND SERVICEPERSONEEL te worden uitgevoerd. Er bevinden zich GEEN ONDERDELEN in de UPS die DOOR DE GEBRUIKER kunnen worden GEREPAREERD.



WAARSCHUWING

- Deze UPS bevat een eigen energiebron (accu's). De UPS-uitgang kan onder spanning staan, zelfs wanneer de UPS niet is aangesloten op de netspanning.
- Teneinde de kans op brand of elektrische schok te verminderen dient deze UPS in een gebouw met temperatuur- en vochtigheidsregeling te worden geïnstalleerd, waar geen geleidende verontreinigingen aanwezig zijn. De omgevingstemperatuur mag 40°C niet overschrijden. Niet gebruiken in de buurt van water of bij zeer hoge vochtigheid (max. 95%).
- Sluit om brandgevaar te voorkomen de apparatuur uitsluitend aan op een circuit voorzien van een overstroombeveiliging voor vertakte circuits van maximaal 100 A in overeenstemming met de National Electrical Code (Nationale Elektriciteitsvoorschriften), ANSI/NFPA 70.

- De uitgangsoverstroombeveiliging en de stroomonderbreker moeten door derden worden geleverd.
- Om aan de internationale normen en bedradingsvoorschriften te voldoen mag de gehele apparatuur die op de uitgang van deze UPS is aangesloten, geen aardlekstroom van meer dan 3,5 milliampère hebben.



OPGELET

- Batterijen leveren gevaar op voor elektrische schokken en kunnen brandwonden veroorzaken door een grote kortsluitstroom. Neem de juiste voorzorgsmaatregelen in acht. Het onderhoud moet worden uitgevoerd door bevoegde onderhoudsmonteurs die verstand hebben van accu's en op de hoogte zijn van de vereiste voorzorgsmaatregelen. Houd onbevoegden uit de buurt van de accu's.
- De batterijen moeten op de juiste wijze worden opgeruimd. Raadpleeg hiervoor uw plaatselijke voorschriften.
- Nooit batterijen in het vuur gooien. De batterijen kunnen ontploffen.

Tarkeita Turvaohjeita

TÄRKEITÄ TURVAOHJEITA - SUOMI SÄILYTÄ NÄMÄ OHJEET

Tämä käyttöohje sisältää tärkeitä ohjeita, joita on noudatettava UPS-virtalähteen ja akkujen asennuksen ja huollon yhteydessä. Lue kaikki ohjeet ennen laitteiston käyttöä ja säilytä ohje myöhempää tarvetta varten.



VAARA

Tämä UPS sisältää HENGENVAARALLISIA JÄNNITTEITÄ. Kaikki korjaukset ja huollot on jätettävä VAIN VALTUUTETUN HUOLTOHENKILÖN TOIMEKSI. UPS ei sisällä MITÄÄN KÄYTTÄJÄN HUOLLETTAVIA OSIA.



VAROITUS

- Tässä UPS-virtalähteessä on oma energianlähde (akut). UPS-virtalähteen lähdössä voi olla jännite, vaikka UPS-virtalähdettä ei ole kytketty verkkovirtaan.
- Vähentääksesi tulipalon ja sähköiskun vaaraa asenna tämä UPS sisätiloihin, joissa lämpötila ja kosteus on säädettävissä ja joissa ei ole virtaa johtavia epäpuhtauksia. Ympäristön lämpötila ei saa ylittää 40 °C. Älä käytä lähellä vettä ja vältä kosteita tiloja (95 % maksimi).

- Pienennä tulipalon vaaraa kytkemällä vain piiriin, jossa on 100 ampeerin maksimihaarapiirin ylivirtasuoja kansallisen sähkölainsäädännön (ANSI/NFPA 70) mukaan.
- Muiden on toimitettava lähdön ylivirtasuoja ja irtikytkentäkytkin.
- Kansainväliset normit ja johdotusmääräykset vaativat, että kaikkien tämän UPS-laitteen ulostulokytkentöjen yhteinen maavuotovirta ei ylitä 3,5 milliampeeria (mA).

VARO



- Akut voivat aiheuttaa sähköiskun tai palovammojen vaaran johtuen suuresta oikosulkuvirrasta. Noudata kaikkia asianmukaisia varotoimia. Laitteen saa huoltaa vain ammattitaitoinen huoltohenkilökunta, joka tuntee akut ja niihin liittyvät varotoimet. Älä päästä valtuuttamatonta henkilöstöä lähelle akkuja.
- Akusto täytyy hävittää säädösten mukaisella tavalla. Noudata paikallisia määräyksiä.
- Älä koskaan heitä akkuja tuleen. Ne voivat räjähtää.

Consignes de sécurité

CONSIGNES DE SÉCURITÉ IMPORTANTES CONSERVER CES INSTRUCTIONS

Ce manuel comporte des instructions importantes que vous êtes invité à suivre lors de toute procédure d'installation et de maintenance des batteries et de l'onduleur. Veuillez consulter entièrement ces instructions avant de faire fonctionner l'équipement et conserver ce manuel afin de pouvoir vous y reporter ultérieurement.

DANGER!



Cet onduleur contient des TENSIONS MORTELLES. Toute opération d'entretien et de réparation doit être EXCLUSIVEMENT CONFIEE A UN PERSONNEL QUALIFIE AGRÉÉ. AUCUNE PIÈCE RÉPARABLE PAR L'UTILISATEUR ne se trouve dans l'onduleur.

AVERTISSEMENT!



- Cette onduleur possède sa propre source d'alimentation (batteries). Il est possible que la sortie de l'onduleur soit sous tension même lorsque l'onduleur n'est pas connectée à une alimentation CA.
- Pour réduire les risques d'incendie et de décharge électrique, installer l'onduleur uniquement à l'intérieur, dans un lieu dépourvu de matériaux conducteurs, où la température et l'humidité ambiantes sont contrôlées. La température ambiante ne doit pas dépasser 40 °C. Ne pas utiliser à proximité d'eau ou dans une atmosphère excessivement humide (95 % maximum).

- Afin de réduire les risques d'incendie, ne raccordez qu'à un circuit muni d'une protection de surintensité du circuit de dérivation maximum de 100 ampères conformément au Code Électrique National (National Electrical Code) des États-Unis, ANSI/NFPA 70.
- La protection de surintensité de sortie ainsi que le sectionneur doivent être fournis par des tiers.
- Afin d'être conforme aux normes et règlements internationaux de câblage, le courant de fuite à la terre de la totalité du matériel branché sur la sortie de l'onduleur ne doit pas dépasser 3,5 mA.



ATTENTION!

- Les batteries peuvent présenter un risque de choc électrique ou de brûlure provenant d'un courant de court-circuit haute intensité. Observez les précautions appropriées. L'entretien doit être réalisé par du personnel qualifié connaissant bien les batteries et les précautions nécessaires. N'autorisez aucun personnel non qualifié à manipuler les batteries.
- Une mise au rebut réglementaire des batteries est obligatoire. Consulter les règlements en vigueur dans votre localité.
- Ne jamais jeter les batteries au feu. L'exposition aux flammes risque de les faire exploser.

Sicherheitswarnungen

WICHTIGE SICHERHEITSANWEISUNGEN AUFBEWAREN

Dieses Handbuch enthält wichtige Anweisungen, die Sie während der Installation und Wartung des USV (Unterbrechungsfreies Stromversorgungssystem) und der Batterien befolgen müssen. Bitte lesen Sie alle Anweisungen des Handbuchs bevor sie mit dem Gerät arbeiten. Bewahren Sie das Handbuch zum Nachlesen auf.



WARNUNG

Die USV führt lebensgefährliche Spannungen. Alle Reparatur- und Wartungsarbeiten sollten nur von Kundendienstfachleuten durchgeführt werden. Die USV enthält keine vom Benutzer zu wartenden Komponenten.



ACHTUNG

- Dieses USV (Unterbrechungsfreies Stromversorgungssystem) enthält eine eigene Energiequelle (Batterien). Der USV-Ausgang kann Spannung führen, auch wenn das USV nicht an eine Wechselstromquelle angeschlossen ist.
- Um die Brand- oder Elektroschockgefahr zu verringern, diese USV nur in Gebäuden mit kontrollierter Temperatur und Luftfeuchtigkeit installieren, in denen keine leitenden Schmutzstoffen vorhanden sind. Die Umgebungstemperatur darf 40°C nicht übersteigen. Die USV nicht in der Nähe von Wasser oder in extrem hoher Luftfeuchtigkeit (max. 95 %) betreiben.
- Um die Brandgefahr zu verringern, nur an eine Leitung anschließen, die mit einem Überlaststromschutz von maximal 100 Ampere in Übereinstimmung mit dem National Electrical Code, ANSI/NFPA 70 ausgestattet ist.
- Der Ausgangs-Überlaststromschutz und der Trennschalter müssen von anderen Herstellern geliefert werden.
- Um internationale Normen und Verdrahtungsvorschriften zu erfüllen, dürfen die an den Ausgang dieser USV angeschlossenen Geräte zusammen einen Erdableitstrom von insgesamt 3,5 Milliampere nicht überschreiten.



VORSICHT!

- Batterien können das Risiko eines elektrischen Schlags bergen oder durch hohen Kurzschlussstrom in Brand geraten. Die richtigen Vorsichtsmaßnahmen beachten. Die Wartung muss von qualifiziertem Wartungspersonal durchgeführt werden, das im Umgang mit Batterien geübt ist und über gute Kenntnisse der erforderlichen Vorsichtsmaßnahmen verfügt. Nicht autorisiertes Personal von Batterien fern halten.
- Die Batterien müssen ordnungsgemäß entsorgt werden. Hierbei sind die örtlichen Bestimmungen zu beachten.
- Batterien niemals verbrennen, da sie explodieren können.

Avvisi di sicurezza

IMPORTANTI ISTRUZIONI DI SICUREZZA CONSERVARE QUESTE ISTRUZIONI

Il presente manuale contiene importanti istruzioni da seguire durante l'installazione e la manutenzione dell'UPS e delle batterie. Leggere integralmente le istruzioni prima di utilizzare l'apparecchiatura e conservare il presente manuale per futuro riferimento.



PERICOLO

La TENSIONE contenuta in questo gruppo statico di continuità è LETALE. Tutte le operazioni di riparazione e di manutenzione devono essere effettuate ESCLUSIVAMENTE DA PERSONALE TECNICO AUTORIZZATO. All'interno del gruppo statico di continuità NON vi sono PARTI RIPARABILI DALL'UTENTE.



AVVERTENZA

- L'UPS contiene la propria fonte di energia (batterie). Le prese d'uscita dell'UPS possono essere sotto tensione anche quando l'UPS non è collegato all'alimentazione elettrica CA.
- Per ridurre il rischio di incendio o di scossa elettrica, installare il gruppo statico di continuità in un ambiente interno a temperatura ed umidità controllata, privo di agenti contaminanti conduttivi. La temperatura ambiente non deve superare i 40°C. Non utilizzare l'unità in prossimità di acqua o in presenza di umidità eccessiva (95% max).
- Per ridurre il rischio di incendio, effettuare il collegamento soltanto a un circuito dotato di una protezione da sovraccarico per il circuito derivato di max. 100 ampere come stabilito dalle norme statunitensi sugli impianti elettrici (National Electrical Code, ANSI/NFPA 70).
- La protezione da sovraccarico per le uscite e l'interruttore di scollegamento devono essere forniti da altri produttori.
- Per conformità con gli standard internazionali e con le norme in merito al cablaggio, tutta l'apparecchiatura collegata con l'uscita del gruppo statico di continuità non deve avere una corrente di dispersione di terra superiore a 3,5 milliampere.



ATTENZIONE

- Le batterie possono comportare un rischio di scossa elettrica o di ustione in seguito a un'elevata corrente di corto circuito. Osservare le dovute precauzioni. L'assistenza deve essere eseguita da personale qualificato esperto di batterie e delle necessarie precauzioni. Tenere il personale non autorizzato lontano dalle batterie.
- Le batterie devono essere smaltite in modo corretto. Per i requisiti di smaltimento fare riferimento alle disposizioni locali.
- Non gettare mai le batterie nel fuoco poichè potrebbero esplodere se esposte alle fiamme.

Viktig Sikkerhetsinformasjon

VIKTIGE SIKKERHETSINSTRUKSJONER GJEM DISSE INSTRUKSJONENE

Denne håndboken inneholder viktige instruksjoner som du bør overholde ved montering og vedlikehold av UPS-enheten og batteriene. Les alle instruksjoner før utstyret tas i bruk, og gjem håndboken til fremtidig referanse.

FARLIG



Denne UPS'en inneholder LIVSFARLIGE SPENNINGER. All reparasjon og service må kun utføres av AUTORISERT SERVICEPERSONALE. BRUKERE KAN IKKE UTFØRE SERVICE PÅ NOEN AV DELENE i UPS'en.

FARLIG



- UPS-enheten inneholder sin egen energikilde (batterier). UPS-utgangen kan være strømførende selv når UPS-enheten ikke er koblet til et strømuttak.
- For å redusere fare for brann eller elektriske støt, bør denne UPS'en installeres i et innendørs miljø med kontrollert temperatur og luftfuktighet som er fritt for ledende, forurensende stoffer. Romtemperaturen må ikke overskride 40°C. Den må ikke brukes i nærheten av vann eller ved meget høy luftfuktighet (95% maks.).
- For å redusere brannfaren skal det bare kobles til et kretsløp med 100 A maksimum linjeforgrenings overbelastningsbeskyttelse i henhold til National Electrical Code, ANSI/NFPA 70.
- Overbelastningsbeskyttelse for strømutgang og bryterkontakt skal leveres av andre.
- Alt utstyr som er forbundet med utgangen av denne UPS'en må ikke ha en sterkere total lekkasjestrøm enn 3,5 milliamperer for å være i overensstemmelse med internasjonale standarder og forkablingsbestemmelser.

FORSIKTIG



- Batterier kan utgjøre en fare for elektrisk støt eller brannskade pga. høy kortslutningsstrøm. Treff passende forholdsregler. Service bør utføres av kvalifisert servicepersonale med kjennskap til batterier og nødvendige forholdsregler. Hold uautorisert personale borte fra batteriene.
- Batterier må fjernes på korrekt måte. Se lokale forskrifter vedrørende krav om fjerning av batterier.
- Kast aldri batterier i flammer, da de kan eksplodere, hvis de utsettes for åpen ild.

Regulamentos de Segurança

INSTRUÇÕES DE SEGURANÇA IMPORTANTES GUARDE ESTAS INSTRUÇÕES

Este manual contém instruções importantes que devem ser seguidas durante a instalação e manutenção do no-break e das baterias. Leia todas as instruções antes de operar o equipamento e guarde este manual para consultá-lo futuramente.

CUIDADO



A UPS contém VOLTAGEM MORTAL. Todos os reparos e assistência técnica devem ser executados SOMENTE POR PESSOAL DA ASSISTÊNCIA TÉCNICA AUTORIZADO. Não há nenhuma PEÇA QUE POSSA SER REPARADA PELO USUÁRIO dentro da UPS.

ADVERTÊNCIA



- Este no-break possui sua própria fonte de energia (baterias). A saída do no-break pode estar energizada mesmo que este não esteja conectado a uma fonte de energia elétrica.
- Para reduzir o risco de incêndios ou choques elétricos, instale a UPS em ambiente interno com temperatura e umidade controladas e livres de contaminadores condutíveis. A temperatura ambiente não deve exceder 40°C. Não opere próximo a água ou em umidade excessiva (máx: 95%).
- Para reduzir o risco de incêndio, conecte somente ao circuito fornecido com a proteção máxima de 100 ampères contra a sobretensão do circuito derivado, de acordo com a norma ANSI/NFPA 70 do National Electrical Code.
- A proteção contra a sobretensão de saída e o disjuntor deve ser fornecida por terceiros.
- Para estar de acordo com os padrões internacionais e os regulamentos de fiação, o equipamento total conectado à saída desta UPS não deve ter uma corrente de fuga à terra maior que 3,5 miliampères.

PERIGO



- As baterias podem oferecer risco de choque elétrico ou queimadura, ocasionados por alta tensão com possibilidade de curto-circuito. Tome as precauções adequadas. A manutenção deve ser realizada por pessoal qualificado, com conhecimento sobre baterias e ciente das precauções exigidas. Mantenha o pessoal não autorizado afastado das baterias.
- Siga as instruções apropriadas ao desfazer-se das baterias. Consulte os códigos do local para maiores informações sobre os regulamentos de descarte de produtos.
- Nunca jogue as baterias no fogo, porque há risco de explosão.

Предупреждения по мерам безопасности

ВАЖНЫЕ УКАЗАНИЯ ПО МЕРАМ БЕЗОПАСНОСТИ СОХРАНИТЕ ЭТИ УКАЗАНИЯ

В данном руководстве содержатся важные инструкции по установке и обслуживанию источника бесперебойного питания (ИБП) и батарей. Перед работой с оборудованием прочтите все инструкции. Сохраните данное руководство для дальнейшего использования.

ОПАСНО



В данном ИБП имеются СМЕРТЕЛЬНО ОПАСНЫЕ НАПРЯЖЕНИЯ. Все работы по ремонту и обслуживанию должны выполняться ТОЛЬКО УПОЛНОМОЧЕННЫМ ОБСЛУЖИВАЮЩИМ ПЕРСОНАЛОМ. Внутри ИБП нет узлов, ОБСЛУЖИВАЕМЫХ ПОЛЬЗОВАТЕЛЕМ.

ПРЕДУПРЕЖДЕНИЕ



- В данном ИБП установлены собственные источники энергии (батареи). В ИБП может иметься напряжение даже в том случае, если он не подключен к сети переменного тока.
- Для снижения опасности пожара или поражения электрическим током устанавливайте ИБП в закрытом помещении с контролируемыми температурой и влажностью, в котором отсутствуют проводящие загрязняющие вещества. Температура окружающего воздуха не должна превышать 40°C. Не эксплуатируйте устройство около воды или в местах повышенной влажностью (макс. 95%).
- Для того чтобы снизить риск возникновения пожара, при подключении используйте электрическую цепь, снабженную защитой от перегрузки параллельной цепи с максимальной силой тока 100 А (в соответствии с Национальными электротехническими правилами и нормами ANSI / NFPA 70).
- Устройство защиты от перегрузки выходного напряжения и размыкающий переключатель приобретаются отдельно.
- Для обеспечения соблюдения требований международных стандартов и требований к разводке электрических цепей, суммарная величина тока утечки на землю всего оборудования, подключенного к выходу ИБП, не должна превышать 3,5 миллиампера.



ОСТОРОЖНО

- Высокое напряжение, вызванное коротким замыканием в батарее, может привести к поражению электрическим током или ожогу. Соблюдайте меры предосторожности. Техническое обслуживание должно осуществляться квалифицированным персоналом по работе с источниками питания, знакомым с мерами предосторожности. Не допускайте к работе с батареями посторонних.
- Необходимо соблюдать правила утилизации аккумуляторов. Обратитесь к местным нормативным актам за информацией о требованиях к утилизации.
- Никогда не бросайте аккумуляторы в огонь. Аккумуляторы могут взорваться под воздействием огня.

Advertencias de Seguridad

INSTRUCCIONES DE SEGURIDAD IMPORTANTES GUARDE ESTAS INSTRUCCIONES

Este manual contiene instrucciones importantes que debe seguir durante la instalación y el mantenimiento del SIE y de las baterías. Por favor, lea todas las instrucciones antes de poner en funcionamiento el equipo y guarde este manual para referencia en el futuro.



PELIGRO

Este SIE contiene VOLTAJES MORTALES. Todas las reparaciones y el servicio técnico deben ser efectuados SOLAMENTE POR PERSONAL DE SERVICIO TÉCNICO AUTORIZADO. No hay NINGUNA PARTE QUE EL USUARIO PUEDA REPARAR dentro del SIE.



ADVERTENCIA

- Este SIE contiene su propia fuente de energía (baterías). La salida del SIE puede transportar voltaje activo aun cuando el SIE no esté conectado con una fuente de CA.
- Para reducir el riesgo de incendio o de choque eléctrico, instale este SIE en un lugar cubierto, con temperatura y humedad controladas, libre de contaminantes conductores. La temperatura ambiente no debe exceder los 40°C. No trabaje cerca del agua o con humedad excesiva (95% máximo).
- Para reducir el riesgo de incendio, realice la conexión únicamente hacia un circuito que cuente con un máximo de 100 amperios de protección contra sobrecorriente de circuito derivado, de acuerdo con el Código Eléctrico Nacional, ANSI/NFPA 70.

- La protección contra sobrecorriente de salida y el conmutador de desconexión debe suministrarse por parte de terceros.
- Para cumplir con los estándares internacionales y las normas de instalación, la totalidad de los equipos conectados a la salida de este SIE no debe tener una intensidad de pérdida a tierra superior a los 3,5 miliamperios.



PRECAUCIÓN

- Las baterías pueden constituir un riesgo de descarga eléctrica o quemaduras por corriente alta de corto circuito. Adopte las precauciones debidas. Personal calificado de servicio que conozca de baterías y esté al tanto de las precauciones requeridas debe darle servicio al equipo. Mantenga al personal no autorizado alejado de las baterías.
- Es necesario desechar las baterías de un modo adecuado. Consulte las normas locales para conocer los requisitos pertinentes.
- Nunca deseche las baterías en el fuego. Las baterías pueden explotar si se las expone a la llama.

Säkerhetsföreskrifter

VIKTIGA SÄKERHETSFÖRESKRIFTER SPARA DESSA FÖRESKRIFTER

Den här anvisningen innehåller viktiga instruktioner som du ska följa under installation och underhåll av UPS-enheten och batterierna. Läs alla instruktioner innan du använder utrustningen och spara den här anvisningen för framtida referens.



FARA

Denna UPS-enhet innehåller LIVSFARLIG SPÄNNING. ENDAST AUKTORISERAD SERVICEPERSONAL får utföra reparationer eller service. Det finns inga delar som ANVÄNDAREN KAN UTFÖRA SERVICE PÅ inuti UPS-enheten.



VARNING

- Den här UPS-enheten innehåller sin egen energikälla (batterier). UPS-enhetens uttag kan vara spänningsförande även då UPS-enheten inte är ansluten till spänningsnätet.
- Minska risken för brand eller elektriska stötar genom att installera denna UPS-enhet inomhus, där temperatur och luftfuktighet är kontrollerade och där inga ledande föroreningar förekommer. Omgivande temperatur får ej överstiga 40°C. Använd inte utrustningen nära vatten eller vid hög luftfuktighet (max 95 %).

- För att reducera faran för brand får anslutning endast utföras till en krets som skyddas med överbelastningsskydd på maximalt 100 ampere i enlighet med National Electrical Code, ANSI/NFPA 70.
 - Utgående överbelastningssydd och krets brytare måste levereras av annan leverantör.
 - För att överensstämma med internationell standard och installationsföreskrifter får inte den totala utrustning som anslutits till uttagen på denna UPS-enhet ha läcksström som överstiger 3,5 milliampere.
-



VIKTIGT

- Batterierna kan innebära en risk för elektrisk stöt eller brännskada från kortsluten starkström. Iakttag lämpliga försiktighetsåtgärder. Service ska utföras av utbildad servicepersonal med kunskap om batterierna och nödvändiga försiktighetsåtgärder. Håll ej behörig personal borta från batterierna.
 - Batterierna måste avyttras enligt anvisningarna i lokal lagstiftning.
 - Använda batterier får aldrig brännas upp. De kan explodera.
-

Chapter 3 Installation

This section explains:

- Equipment inspection
- Unpacking the cabinet
- Extended Battery Module (EBM) setup and installation (optional)
- UPS setup and installation, including UPS internal batteries
- Parallel installation (optional)
- Initial startup

Inspecting the Equipment

If any equipment has been damaged during shipment, keep the shipping cartons and packing materials for the carrier or place of purchase and file a claim for shipping damage. If you discover damage after acceptance, file a claim for concealed damage.

To file a claim for shipping damage or concealed damage: 1) File with the carrier within 15 days of receipt of the equipment; 2) Send a copy of the damage claim within 15 days to your service representative.



NOTE Check the battery recharge date on the shipping carton label. If the date has expired and the batteries were never recharged, do not use the UPS. Contact your service representative.

Unpacking the Cabinet



CAUTION

- Unpacking the cabinet in a low-temperature environment may cause condensation to occur in and on the cabinet. Do not install the cabinet until the inside and outside of the cabinet are absolutely dry (hazard of electric shock).
 - The cabinet and batteries are heavy (see page 114). A minimum of two people are required to remove the cabinet and batteries from their cartons.
-

To unpack the cabinet and accessories:

1. Cut the pallet straps and remove the large cardboard outer sleeve. Have two people lift the sleeve for ease of removal.
2. Use care when moving and opening the cartons. Leave the components packaged until ready to install.

Do not install the batteries until after the cabinet is installed in the rack.

3. Discard or recycle the packaging in a responsible manner, or store it for future use.

Follow these guidelines when locating the cabinet after unpacking:

- Place the cabinet in a protected area that has adequate airflow and is free of humidity, flammable gas, and corrosion.
- Avoid placing the cabinet on its side. Verify that the air vents on the front and rear of the cabinet are not blocked.

If installing a parallel system, continue to the following section, "Parallel System Setup."

If installing a standalone UPS and optional EBM(s), continue to "EBM Setup" on page 28. Otherwise, continue to "UPS Setup" on page 34.

Parallel System Setup



WARNING

Only qualified service personnel (such as a licensed electrician) shall perform the electrical installation. Risk of electrical shock.

A UPS connected to a BladeUPS Bar with a paralleling line cord is identified as a member of the parallel system. The BladeUPS Bar connects the line and load to a common power bus. Parallel systems can be configured for capacity or redundancy.

The BladeUPS models in a parallel configuration require a dedicated branch circuit that meets the following requirements:

- Circuit with overcurrent protection, depending on parallel configuration:

Table 1. BladeUPS Overcurrent Protection

Number of UPSs in Parallel System	BladeUPS 12	BladeUPS 12i
2	100A	63A
3	150A	75A
4	200A	100A
5	225A	125A
6 (N+1 System)	225A	160A

- Three-phase, 4-wire plus ground, 208Y/120V nominal (BladeUPS 12) or 400Y/230V nominal, 380–415 Vac acceptable (BladeUPS 12i)
- 50/60 Hz
- The breaker must be wall-mounted and be readily accessible to the operator
- Flexible or rigid metal conduit



NOTE For ease of wiring access with bottom entry, place the rack containing the UPSs on a raised floor.

Preparing the Rack

To prepare the rack for wiring:

1. Verify that all packaging material is removed from the rack.
2. Verify that the following items are included with the rack:
 - (4) leveling feet
 - (4) plastic roof caps
 - (2) door keys
 - (1) package M6 screws with plastic washers
 - (1) package matching nuts
3. Verify operation of the rack door handle:

To open the door, push in on the key lock. The handle pops up. Pull out on the handle.

To close the door, push in on the handle until it snaps into place.
4. Verify that the keys lock and unlock the door.
5. (Optional) The rack door may be flipped to allow it to open from the opposite side. To flip the door:

Remove the hinge pins, then remove the door. Move the hinges to the opposite side of the rack. Reorient the door and hang it on the hinges; replace the hinge pins.

Reverse the door handle mounting.



NOTE *The handle uses gravity to operate properly. Reversing the handle is required.*

Move the Eaton Powerware logo to the upper part of the door.

6. Verify that the leveling feet are long enough to lower to the floor. Leveling feet that function solely as pallet bolt supports may need to be replaced with longer versions. For safety, have one person tilt the cabinet while a second person switches the feet.

7. (Optional) For ease of installation, remove the rack side panels, especially the panel on the side nearest the BladeUPS Bar.
8. Plan where each cabinet will be located in the rack and determine the “U” marks to use for mounting the rails. For example, for a rack containing six UPSs and a bottom wireway, plan to mount the bottom of the rails at the following marks (see Figure 3):

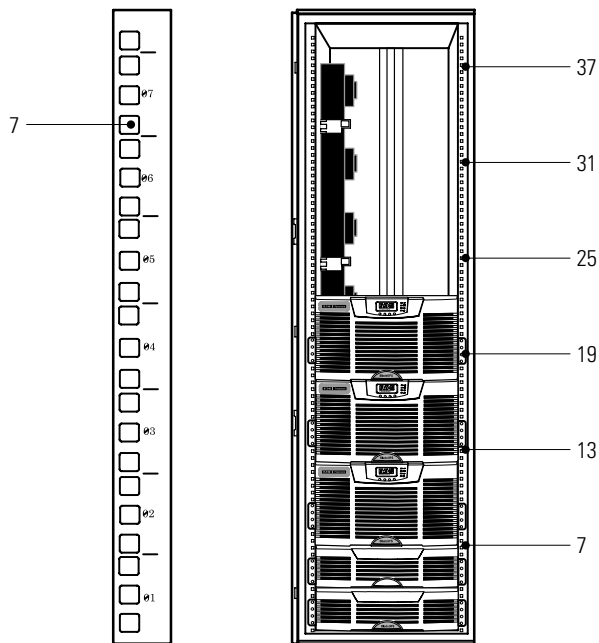

Figure 3. Recommended Rail Locations (Example Configuration)



NOTE Recommended rail locations are for example only. Adjust the locations as needed for your system’s configuration. Allow for hole spacing and numbering (see Figure 3). For guidelines for configuring a parallel system with EBMs, see page 4.

9. Continue to the following section, “Installing the Input and Output Wiring.”

Installing the Input and Output Wiring

To install the parallel system input and output wiring:

1. Remove the four screws on the wireway access cover and retain. Remove the cover and retain. See Figure 4.

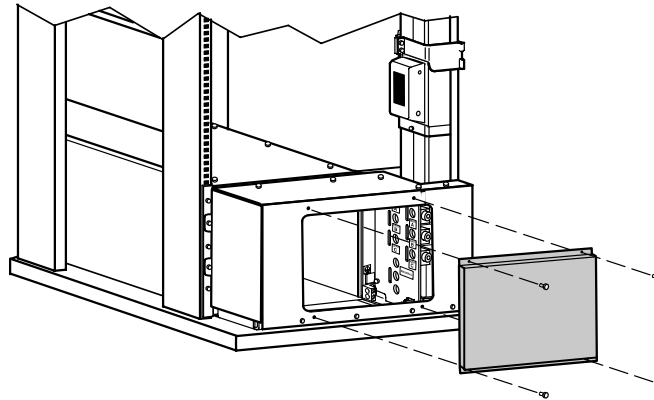

Figure 4. Removing the Wireway Access Cover (Bottom Entry Shown)

2. If your rack is designed for bottom entry but you need to provide top entry wiring, skip to Step 7 on page 26. Otherwise, continue to Step 3.

- 3. Remove the eight screws on the wireway top cover and retain. Slide the cover back and off the wireway and retain. See Figure 5.

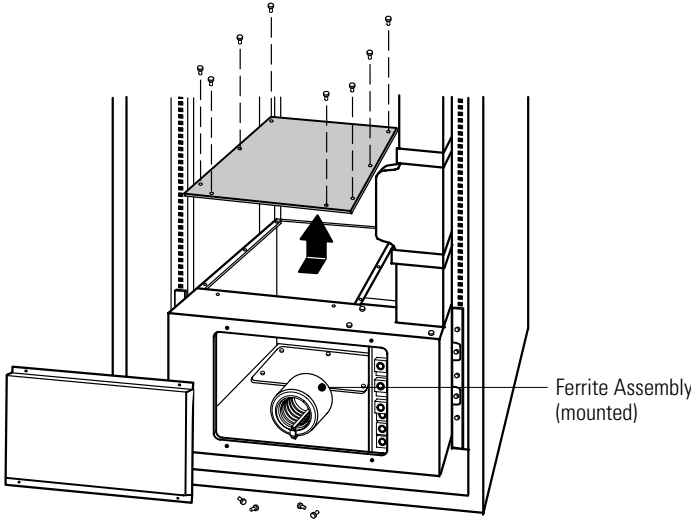

Figure 5. Removing the Wireway Top Cover (Bottom Entry Shown)

- 4. Remove the six screws on the conduit landing plate and retain. Remove the plate and retain. See Figure 6.

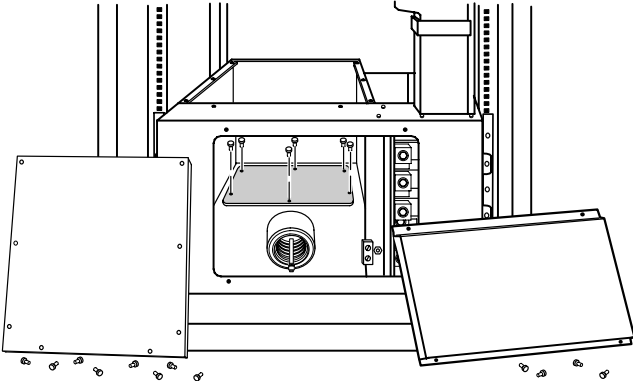

Figure 6. Removing the Conduit Landing Plate (Bottom Entry Shown)

5. Use a Greenlee® punch to provide one or more holes in the conduit landing plate to accommodate the input and output wiring from the utility to the BladeUPS Bar.

Replace the conduit landing plate.

6. Skip to Step 8.
7. **Top entry wiring in a bottom entry rack only.** Use a Greenlee punch to provide one or more holes in the top of the wireway. Install one or more holes in the center rear of the top of the rack. See Figure 7.



NOTE Verify that top entry wiring in a bottom entry rack does not interfere with access areas for the fans, connectors, breakers, or X-Slot cards on any BladeUPS.

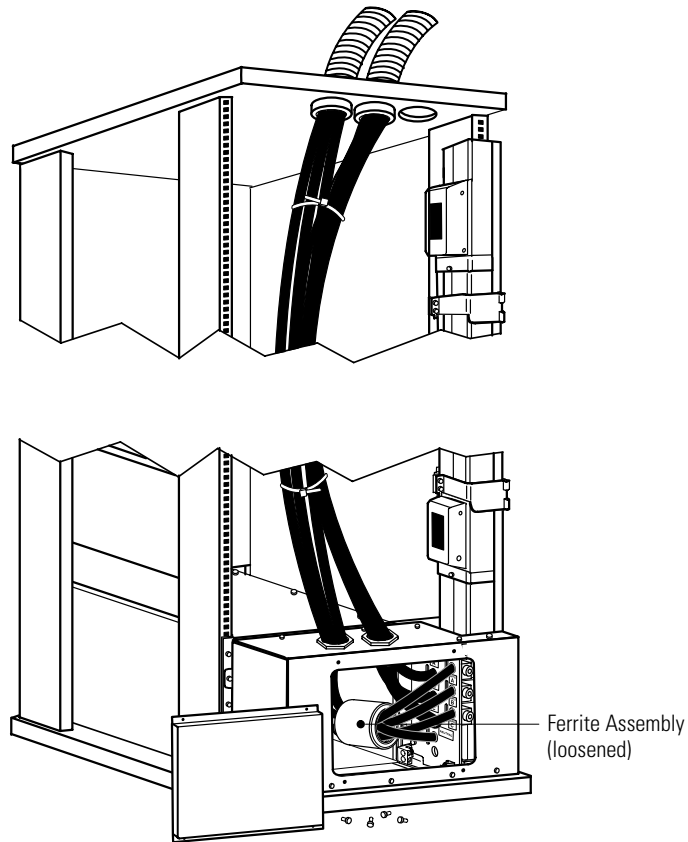

Figure 7. Top Entry Wiring in a Bottom Entry Rack

8. Connect the input, output, and ground wires to the BladeUPS Bar terminal block according to Figure 8 and Table 2. Route the three input phases and the input neutral through the mounted or loosened ferrite assembly (see Figure 5 or Figure 7).

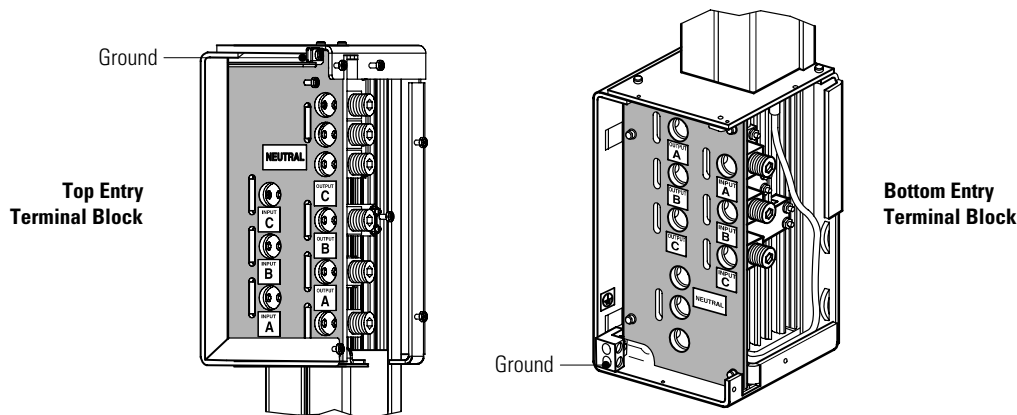

Figure 8. BladeUPS Bar Terminal Block

Table 2. BladeUPS Bar Wiring Specifications

BladeUPS Bar Terminal Block	Terminal Position	BladeUPS Bar Wire Function	Terminal Wire Size Rating*	Tightening Torque
Output	1 [Output A]	Phase 1 Out	13.3 mm ² (6 AWG) to 177 mm ² (350 kcmil)	31.1 Nm (275 lb in)
	2 [Output B]	Phase 2 Out		
	3 [Output C]	Phase 3 Out		
Input	4 [Input A]	Phase 1 In	NOTE Wire gauge depends on overcurrent protection rating required (see Table 1 on page 21). Reference the NEC, NFPA 70, for wire sizing.	
	5 [Input B]	Phase 2 In		
	6 [Input C]	Phase 3 In		
Neutral	7	Neutral	Reference the NEC, NFPA 70, for wire sizing.	
	8	Neutral		
	9	Neutral		
Safety Ground	Ground	Ground	18 mm ² (4 AWG) to 215 mm ² (400 kcmil)	1.8 Nm (16 lb in)

* Use 13.3 mm² (6 AWG) 90°C copper wire minimum.

9. Replace the wireway top cover (does not apply to top entry wiring in a bottom entry rack) and the wireway access cover.
10. If installing optional EBM(s), continue to the following section, "EBM Setup." Otherwise, continue to "UPS Setup" on page 34.

EBM Setup

The BladeUPS EBM comes with all hardware required for installation in a standard EIA or JIS seismic rack-mount configuration with square and round mounting holes. The rail assemblies adjust to mount in 48-cm (19-inch) racks with front to rear rail distances from 61 to 76 cm (24 to 30 inches) deep.

Checking the EBM Accessories

Verify that the following items are included with the EBM:

- EBM front cover
- Mounting brackets and fasteners (if not already installed):
 - (2) mounting brackets
 - (4) 6-32 flat-head screws
- Rails and fasteners:
 - (2) sliding rail assemblies (left and right)
 - (2) rear hold-down brackets
 - (12) hex-head screws
 - (4) U-shaped 10-32 clip nuts
- EBM user's guide



NOTE Discard the EBM user's guide if you are installing the EBM with a new UPS at the same time. Use the UPS user's guide instead to install both the UPS and the EBM.

Rack Setup for the EBM



CAUTION

The EBM is heavy (see page 114). A minimum of two people are required to remove the EBM from its carton.



NOTE Mounting rails are required for each individual cabinet.

To install the EBM rail kit:

1. Loosen the assembly wing nuts on both rail assemblies and adjust the rail size for the depth of your rack (see Figure 9).

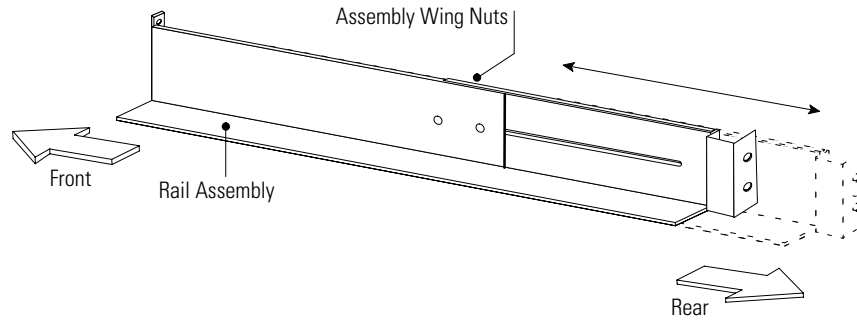

Figure 9. Adjusting the Rail Depth

2. Select the proper holes in the rail for positioning the EBM and other cabinets in the rack.

Place the first rail for the first EBM at the bottom, using positions 1 and 6 for the front hex-head screws. If you are installing additional rails, place the next rail 4 holes above the last installed screw (see Figure 10).



NOTE Verify that the hole patterns on the rails and mounting brackets align with the hole pattern on the rack.

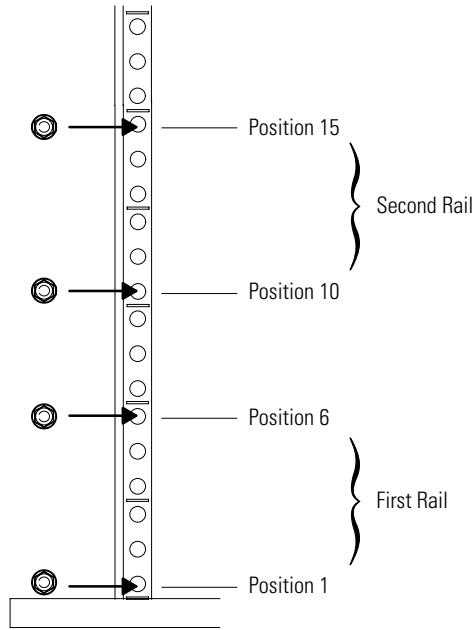

Figure 10. Front Rail Screw Positions for the EBM

3. Secure the rail to the front of the rack with two hex-head screws (see Figure 11).

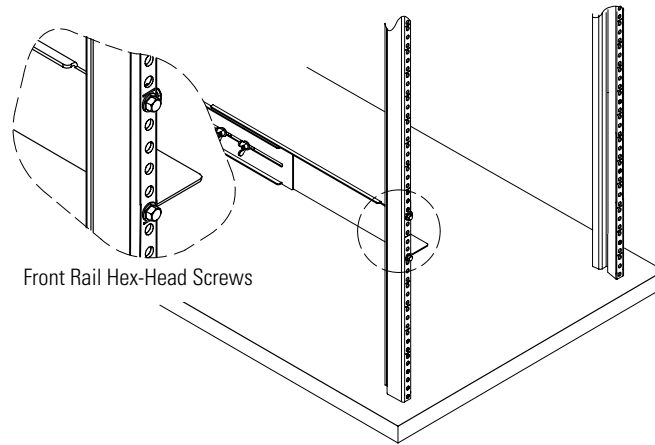

Figure 11. Securing the Front Rail

- 4. Using two clip nuts and two hex-head screws, attach the rail to the rear of the rack (see Figure 12 and Figure 13).

The bottom rail uses positions 2 and 4 for the rear hex-head screws. If you are installing additional rails, place the next rail 7 holes above the last installed screw.

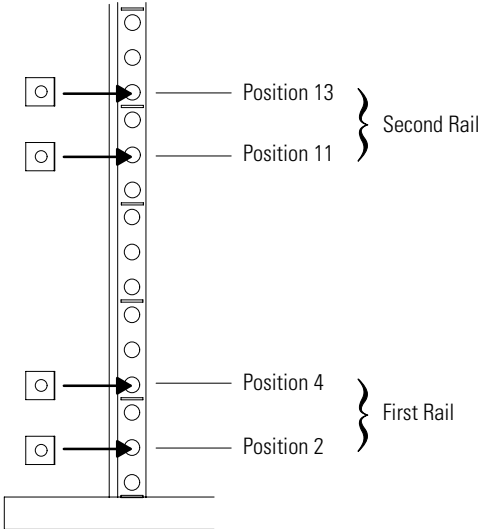

Figure 12. Rear Rail Screw Positions for the EBM

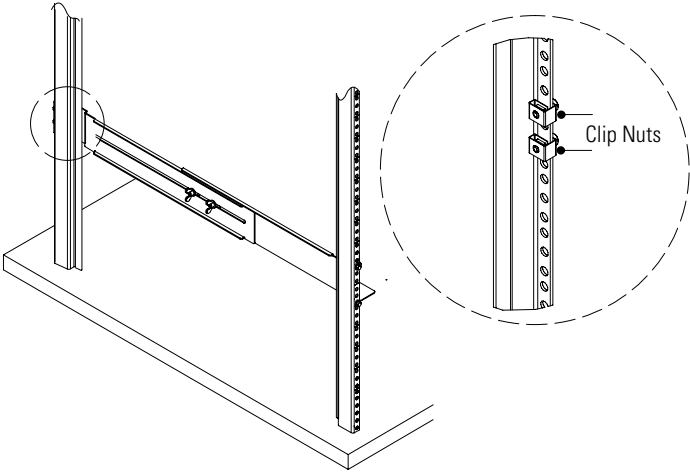

Figure 13. Securing the Rear Rail

5. Repeat Steps 3 and 4 for the other rail.
6. Tighten the assembly wing nuts on both rail assemblies.



CAUTION

The EBM is heavy (see page 114). A minimum of two people are required to move the EBM.

7. Place the EBM on a flat, stable surface with the front of the EBM facing toward you.
8. If the mounting brackets are not already installed, align the two mounting brackets with the screw holes on the side of the EBM and secure with the supplied 6-32 flat-head screws (see Figure 14).
9. Attach the EBM front cover:

Align the pins on the rear of the front cover with the openings in the EBM. Push the cover firmly into place. See Figure 14.

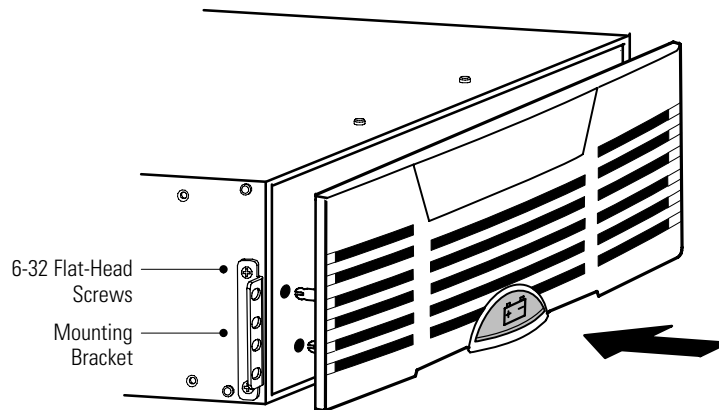

Figure 14. Installing the EBM Mounting Brackets

10. Slide the EBM into the rack.

11. Secure the front of the EBM to the rack using two hex-head screws in each mounting bracket as shown in Figure 15.

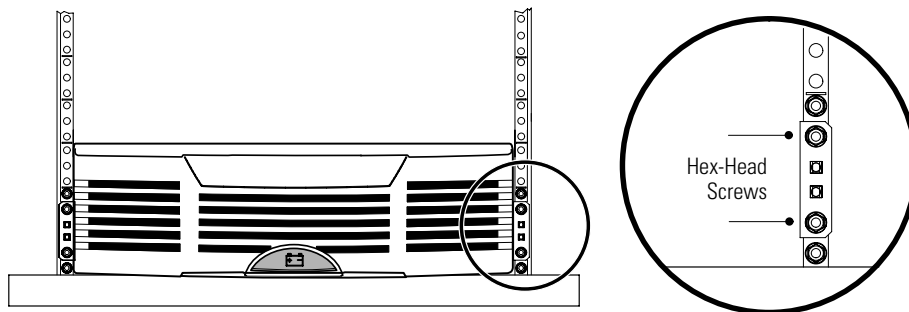

Figure 15. Securing the EBM Mounting Brackets

12. Attach the rear hold-down brackets to the rail and slide the brackets into the slots on the EBM rear panel (see Figure 16).

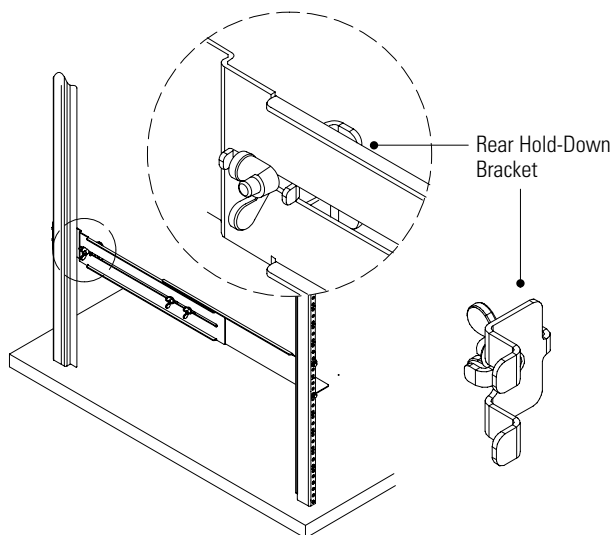

Figure 16. Securing the Back of the EBM

13. Verify that the brackets are seated firmly, then tighten the wing nuts on the rear hold-down brackets. The EBM is now secured in the rack.
14. Continue to the following section, "UPS Setup."

UPS Setup

The BladeUPS UPS comes with all hardware required for installation in a standard EIA or JIS seismic rack-mount configuration with square and round mounting holes. The rail assemblies adjust to mount in 48-cm (19-inch) racks with front to rear rail distances from 61 to 76 cm (24 to 30 inches) deep.

Checking the UPS Accessories

Verify that the following items are included with the UPS:

- UPS front cover
- Rear panel terminal block connectors:
 - (4) two-position connectors
 - (2) two-position connectors with jumpers
 - (1) three-position connector
- Software Suite CD
- This user's guide
- Mounting brackets and fasteners (if not already installed):
 - (2) mounting brackets
 - (8) 6-32 flat-head screws
- Rails and fasteners:
 - (2) sliding rail assemblies (left and right)
 - (2) rear hold-down brackets
 - (16) M5 machine screws
 - (8) M5 clip nuts for racks with round holes
 - (8) M5 cage nuts for racks with square holes
 - (8) M6 hex nuts with integrated washers

Parallel system only. Verify that the following items are included with each Powerware Hot Sync CAN Bridge Card:

- CAN Bridge Card cable with (2) RJ-45 connectors
- Redundant signal cable with (2) two-position terminal block connectors
- Initializing jumper with single RJ-45 connector

Rack Setup for the UPS



CAUTION
The UPS is heavy (see page 114). A minimum of two people are required to remove the UPS from its carton. Use the corrugated lifting sling (packaged with the UPS) to move the UPS.



NOTE Mounting rails are required for each individual cabinet.

To install the UPS rail kit:

1. Select the proper holes in the rack for positioning the UPS in the rack (see Figure 17).



NOTE The UPS takes up position 1 through position 12.
NOTE Verify that the hole patterns on the rails and mounting brackets align with the hole pattern on the rack.

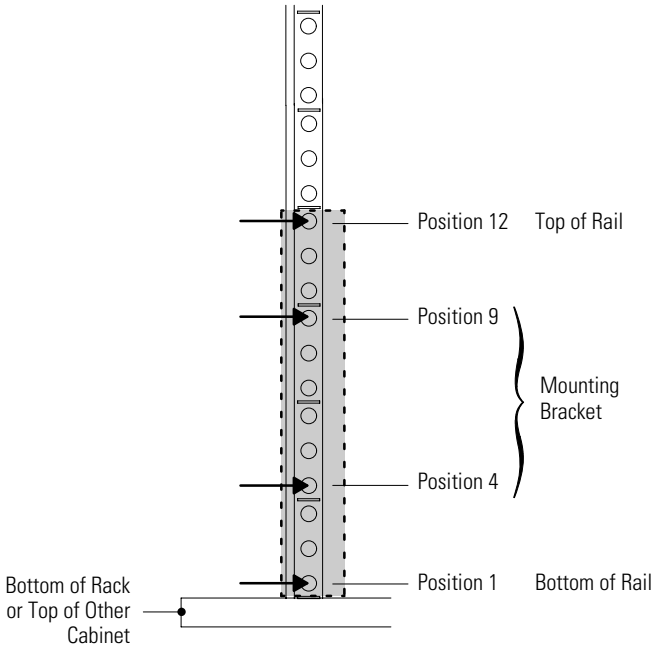

Figure 17. Front Rail Screw Positions for the UPS

2. Pre-assemble four M6 hex nuts to the rail assembly:

Assemble two of the nuts and the rear hold-down bracket and finger-tighten only. Assemble the other two nuts to the rail and finger-tighten only. See Figure 18.

Repeat for the other rail.

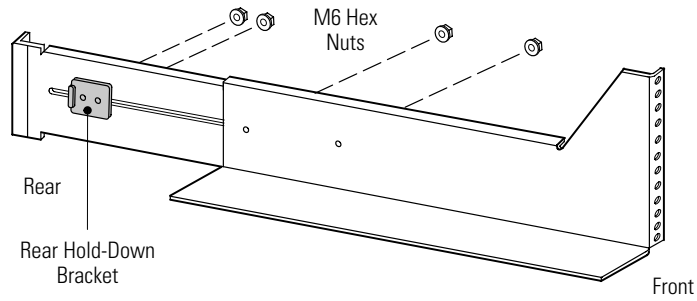

Figure 18. Installing the Rail Hardware (Right Rail Assembly Shown)



NOTE Verify that the holes in the rail align properly with the hole pattern in the rack.

3. Using two M5 machine screws, attach the rail to the front of the rack and finger-tighten only (see Figure 17 and Figure 19).

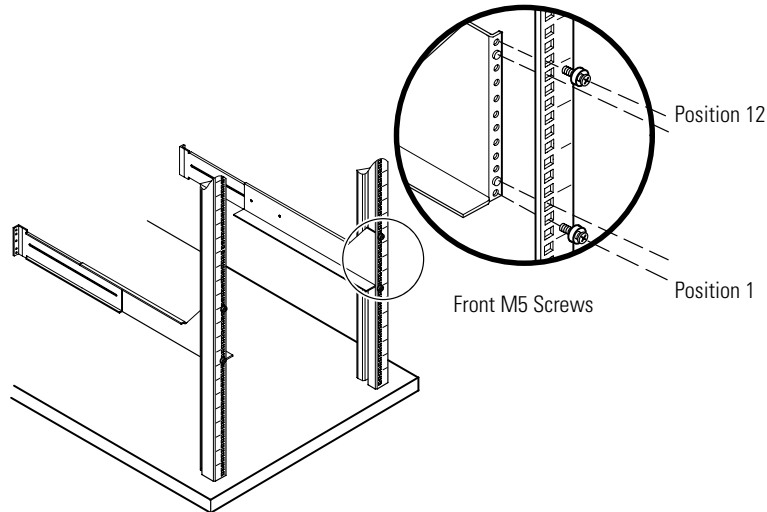

Figure 19. Securing the Front Rail

- 4. Adjust the rail size on the rail assembly for the depth of your rack.
- 5. Secure the rail to the rear of the rack with four M5 machine screws and clip or cage nuts (see Figure 20).

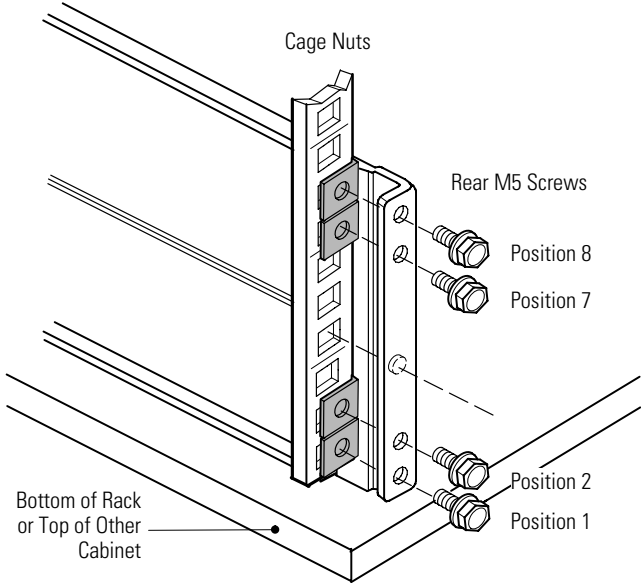

Figure 20. Securing the Rear Rail (Right Rail Assembly Shown)

- 6. Tighten all screws at the front and rear of the rail, then tighten the rail adjustment screws.

Leave the screws through the hold-down brackets loose.
- 7. Repeat Steps 3 through 6 for the other rail.
- 8. **Parallel system only.** (Optional) Repeat Steps 1 through 7 to install each rail kit in the parallel system.



NOTE For ease of installation, it is recommended to install all of the rail kits for the parallel system before installing the UPSs.



CAUTION

The UPS is heavy (see page 114). A minimum of two people are required to remove the UPS from its carton. Use the corrugated lifting sling (packaged with the UPS) to move the UPS.

9. Place the UPS on a flat, stable surface with the front of the UPS facing toward you.
10. Remove the electronics module and set it aside (see Figure 21):

Remove the electronics module locking screw at the top left of the electronics module and retain. Grasp the ring handle at the middle of the module and pull the module slowly out of the cabinet. Pull firmly to unseat the connectors. Use two hands to support the module.



NOTE Treat the electronics module with care to avoid damaging the fans, connectors, or internal circuitry.

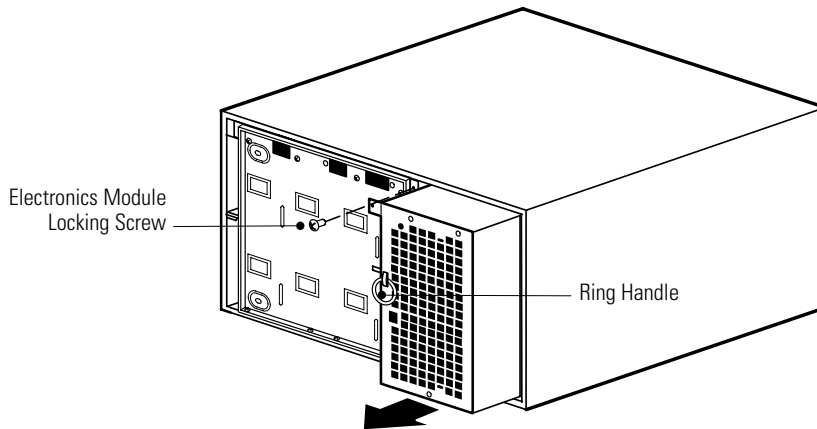

Figure 21. Removing the Electronics Module

- 11. If the mounting brackets are not already installed, align the two mounting brackets with the screw holes on the sides of the UPS and secure with the supplied 6-32 flat-head screws (see Figure 22).

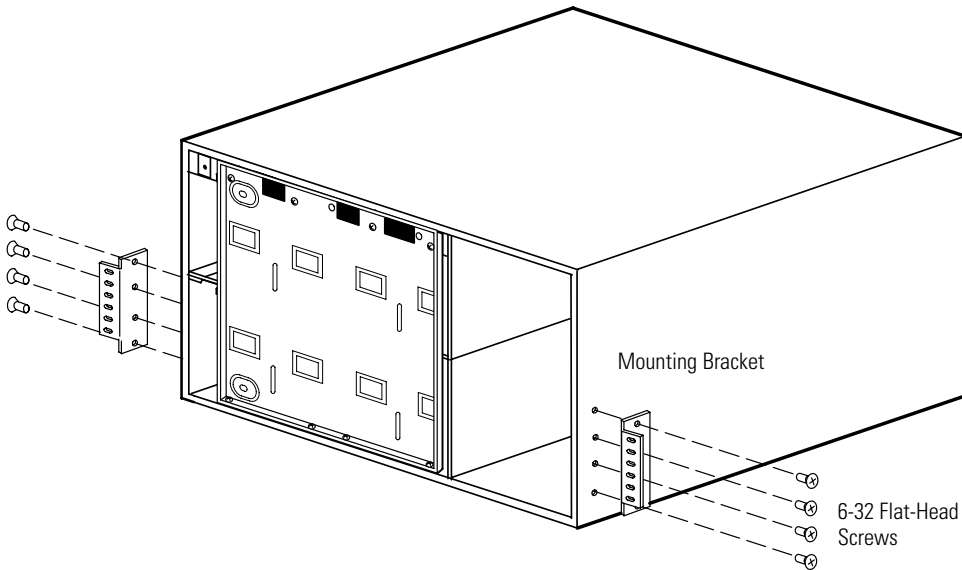

Figure 22. Installing the UPS Mounting Brackets

- 12. Slide the UPS into the rack.
- 13. **Parallel or parallel-ready system only.** If you are installing other X-Slot cards besides the Powerware Hot Sync CAN Bridge Card, skip to Step 16.



NOTE Leaving the UPS unattached allows you to adjust the UPS position in the rack for any clearance needed to install the X-Slot cards.

14. Using four M5 machine screws, secure the front of the cabinet to the rack as shown in Figure 23.

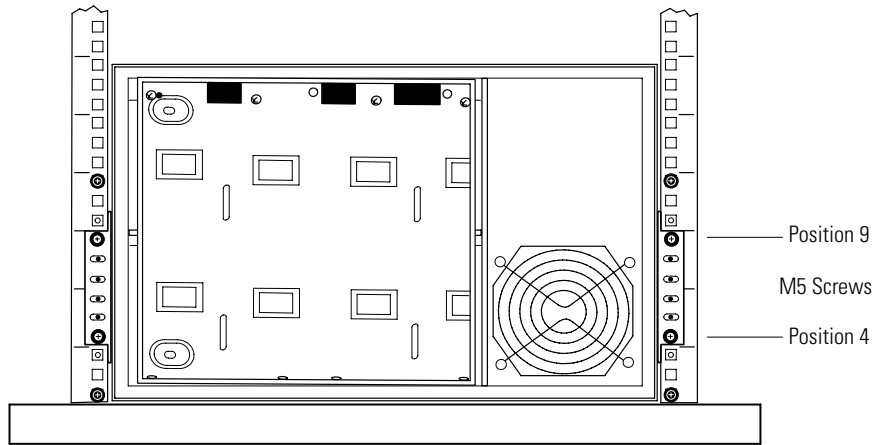

Figure 23. Securing the Front of the UPS

15. Insert the two rear hold-down brackets on the rails into the slots on the rear of the cabinet (see Figure 24).

If necessary, push out on the rack upright to allow the clearance needed to insert the bracket. The rack upright flexes easily.

Verify that the brackets seat firmly, then tighten the nuts on the rear hold-down brackets. The UPS is now secured in the rack.

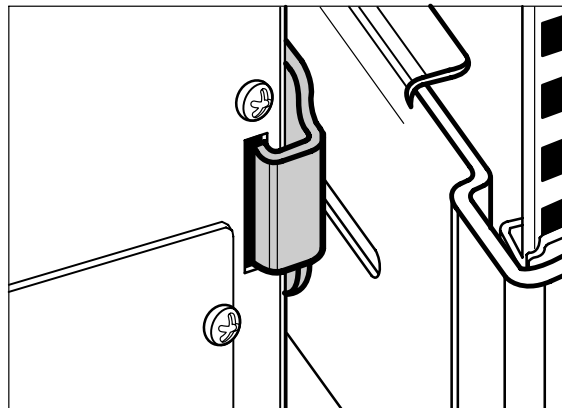

Figure 24. Inserting the Rear Hold-Down Bracket



NOTE Treat the electronics module with care to avoid damaging the fans, connectors, or internal circuitry.

- 16. Replace the electronics module by sliding it carefully into the cabinet. Push the electronics module firmly to seat the connectors.
- 17. Reinstall the electronics module locking screw (see Figure 21 on page 38).
- 18. On the UPS rear panel, plug in the supplied communication terminal block connectors as shown in Figure 25.

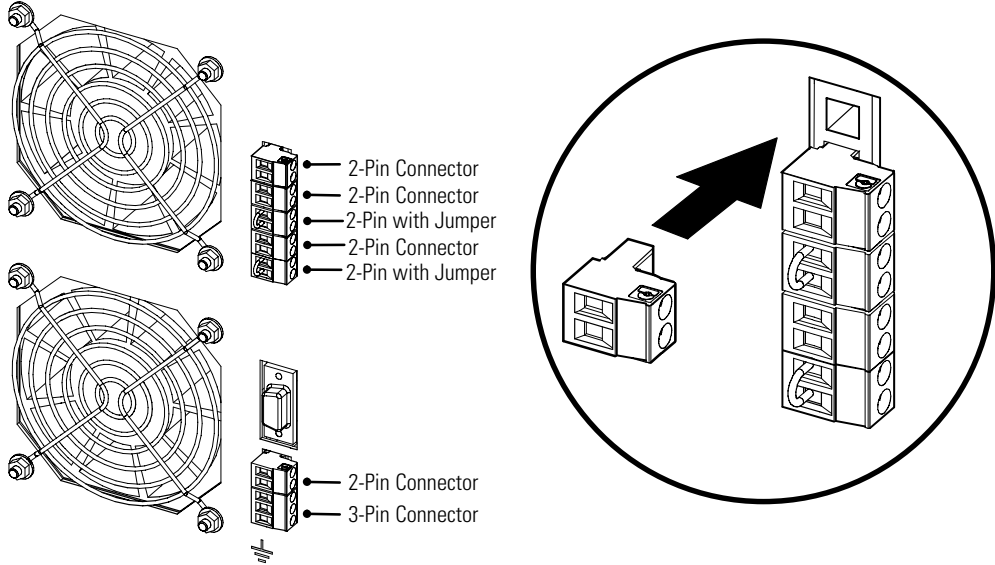

Figure 25. Installing the Communication Terminal Block Connectors

- 19. Continue to the following section, "Installing the UPS Internal Batteries."

Installing the UPS Internal Batteries



CAUTION

The UPS internal batteries are heavy (see page 114). Each battery tray holds two rows of five batteries. Use caution when handling the heavy battery trays.

To install the battery trays into the UPS cabinet:

1. Verify that the circuit breakers on the UPS rear panel are in the OFF (O) position (see Figure 32 on page 49).
2. Remove the eight screws on the battery cover plate and retain. Remove the plate and retain. See Figure 26.

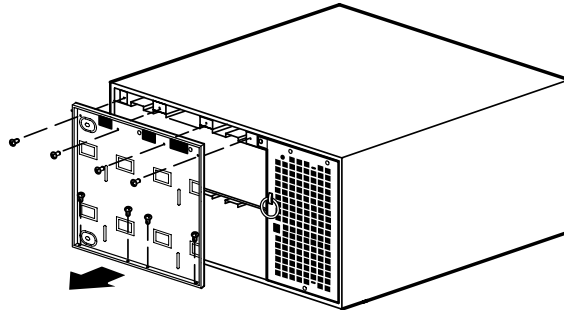

Figure 26. Removing the UPS Battery Cover Plate

3. Slide the battery trays into the cabinet (see Figure 27). Verify each tray is properly aligned before sliding the tray in.

When a tray is fully installed, tuck the plastic handle on the end of the tray into place.

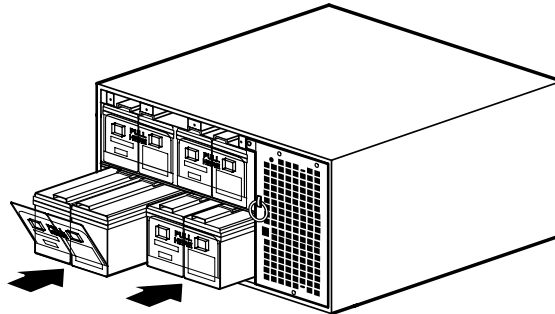

Figure 27. Installing the UPS Battery Trays

4. Reinstall the battery cover plate.
5. Install the UPS front cover (see Figure 28):

Plug the LCD cable from the control panel on the front cover into the connector on the electronics module. Use care to gently loop the LCD cable in front of the electronics module.

Push the top of the front cover firmly into place, and then push the bottom firmly into place.

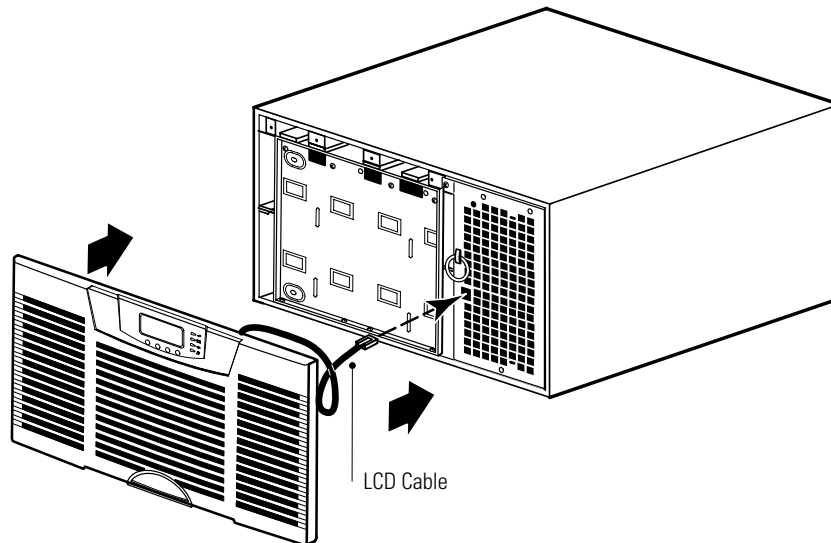

Figure 28. Installing the UPS Front Cover

6. **Parallel system only.** Repeat the steps starting at the beginning of this chapter (page 19) for each UPS to be paralleled.
7. If you are installing an optional EBM, continue to the following section, "EBM Installation." Otherwise, continue to "Standalone UPS Installation" on page 48 or "Parallel UPS Installation" on page 50.

EBM Installation



CAUTION

A small amount of arcing may occur when connecting an EBM to the UPS. This is normal and will not harm personnel. Insert the EBM cable into the UPS battery connector quickly and firmly.

To install the optional EBM(s) for a UPS:

1. Verify that all battery circuit breakers are in the OFF (O) position (see Figure 29).
2. Plug the EBM cable(s) into the battery connector(s) as shown in Figure 29. Up to four EBMs may be connected to the UPS.
3. **Parallel system only.** Repeat Steps 1 and 2 for each UPS with EBM(s).

See Figure 30 on page 46 and Figure 31 on page 47 for examples of EBM connections in a parallel system.

4. Continue to “Standalone UPS Installation” on page 48 or “Parallel UPS Installation” on page 50.

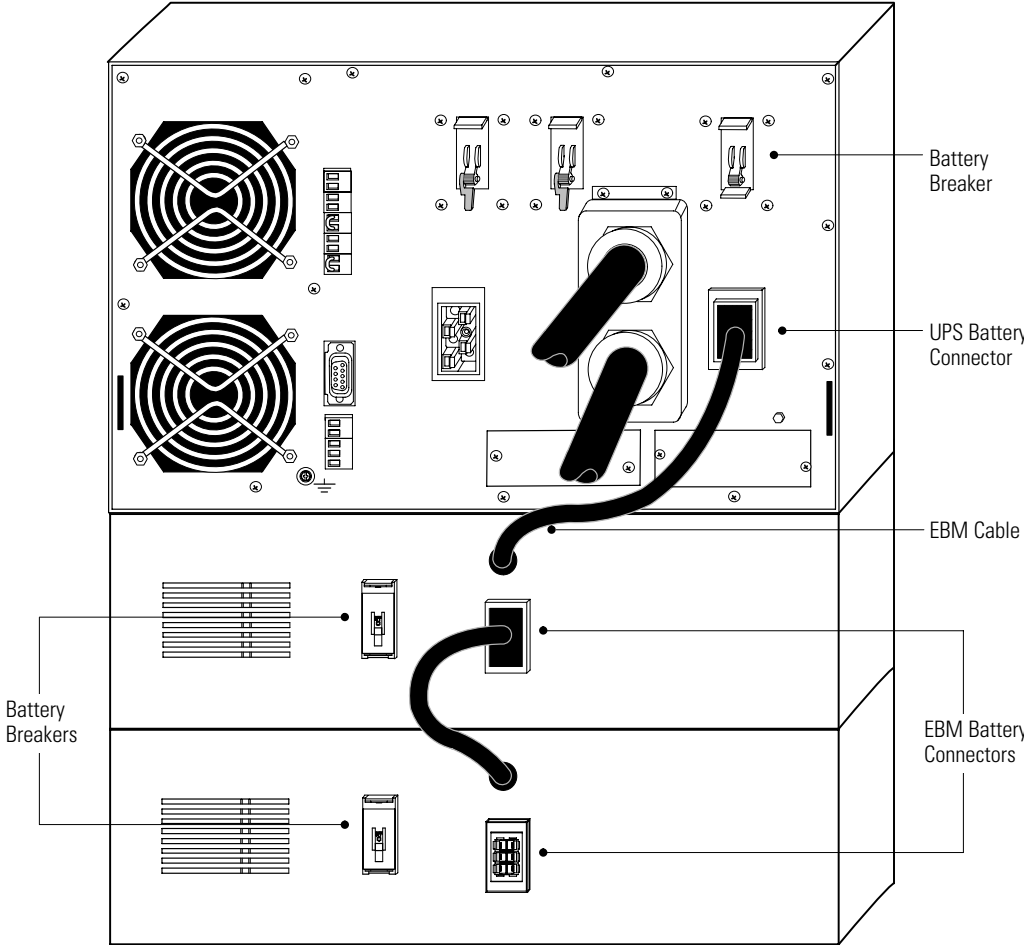

Figure 29. Typical EBM Installation

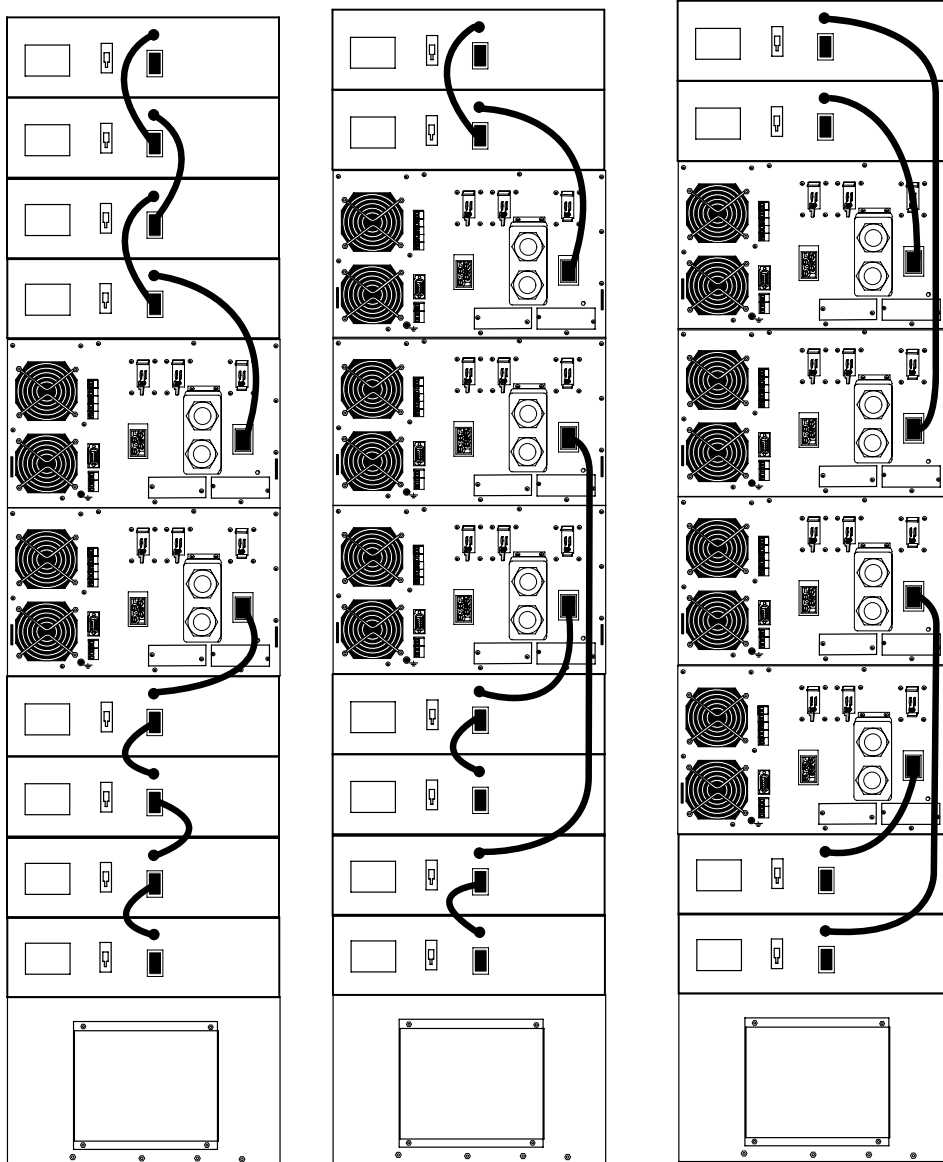

Figure 30. Example EBM Installations in Parallel Systems



NOTE Figure 30 shows two systems using optional 0.9m (3 ft) battery extension cables.

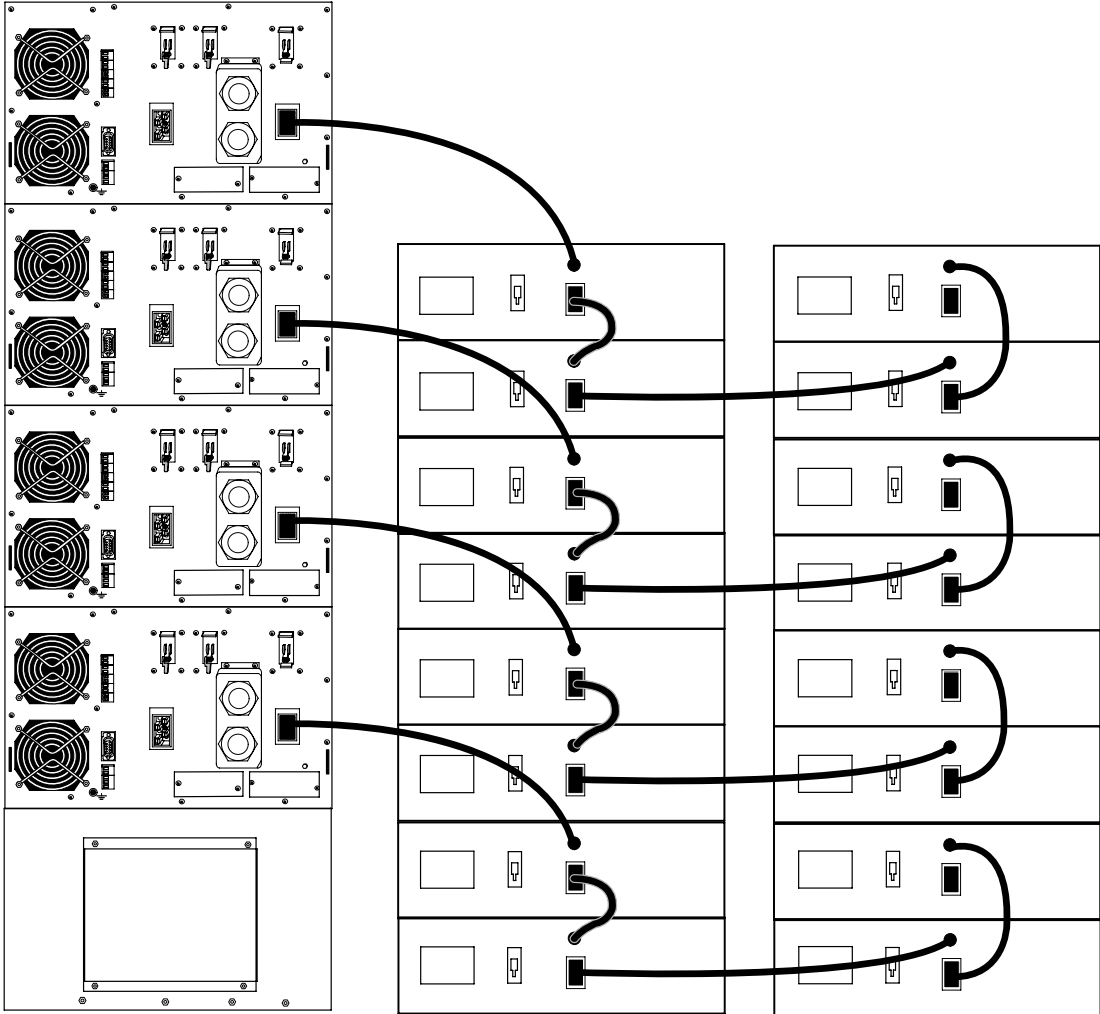

Figure 31. Example EBM Installation in a Large Parallel System



NOTE Figure 31 shows a system using optional 0.9m (3 ft) battery extension cables.

Standalone UPS Installation



NOTE Do not make unauthorized changes to the UPS; otherwise, damage may occur to your equipment and void your warranty.

The BladeUPS models require a dedicated branch circuit that meets the following requirements:

- 50A (BladeUPS 12) or 30A (BladeUPS 12i) circuit with overcurrent protection
- Three-phase, 4-wire plus ground, 208Y/120V nominal (BladeUPS 12) or 400Y/230V nominal, 380–415 Vac acceptable (BladeUPS 12i)
- 50/60 Hz
- The breaker must be wall-mounted and be readily accessible to the operator

To install the UPS:

1. Switch off utility power to the distribution point where the UPS will be connected. Be absolutely sure there is no power.
2. Verify that all circuit breakers are in the OFF (O) position.



NOTE The load connector breaker controls the load connector only, not the output power cord.

3. If you are installing power management software, connect your computer to the UPS communication port or optional X-Slot card (see page 89). For the communication port, use the supplied serial cable.
4. If your rack has conductors for grounding or bonding of ungrounded metal parts, connect the ground cable (not included) to the ground bonding screw. See Figure 32 for the location of the ground bonding screw.
5. If an emergency power-off (disconnect) switch is required by local codes, see “Remote Emergency Power-off” on page 95 to install the REPO switch before powering on the UPS.
6. Continue to “Standalone UPS Initial Startup” on page 66.

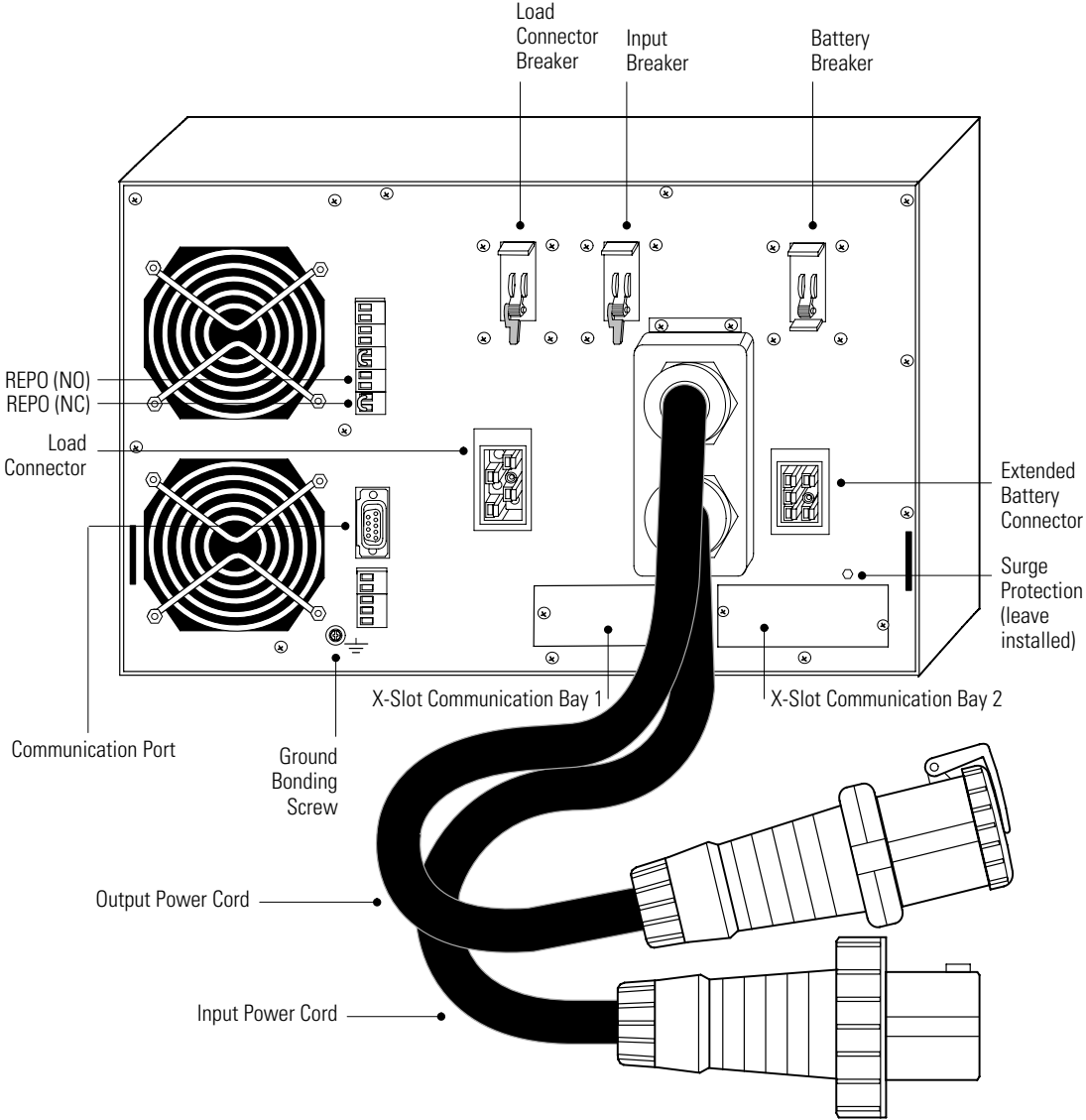

Figure 32. BladeUPS Rear Panel (Standalone UPS Shown with IEC 309-60A Output Power Cord)



NOTE The load connector breaker controls the load connector only, not the output power cord.

Parallel UPS Installation

Follow the appropriate procedure for the type of parallel configuration.

Multiple Parallel UPS Installation

WARNING



Only qualified service personnel (such as a licensed electrician) shall perform the electrical installation. Risk of electrical shock.



NOTE Do not make unauthorized changes to the UPSs; otherwise, damage may occur to your equipment and void your warranty.

To install two to six UPSs in a parallel configuration:

1. Verify that the UPSs to be paralleled are installed in individual rail kits in a rack containing a BladeUPS Bar.
2. Switch off utility power to the distribution point where the parallel system will be connected. Be absolutely sure there is no power.
3. Verify that all circuit breakers are in the OFF (O) position.



NOTE The load connector breaker controls the load connector only, not the output power cord.

4. Unpack the Powerware Hot Sync CAN Bridge Card and verify that the card was not damaged during shipment (see Figure 33).

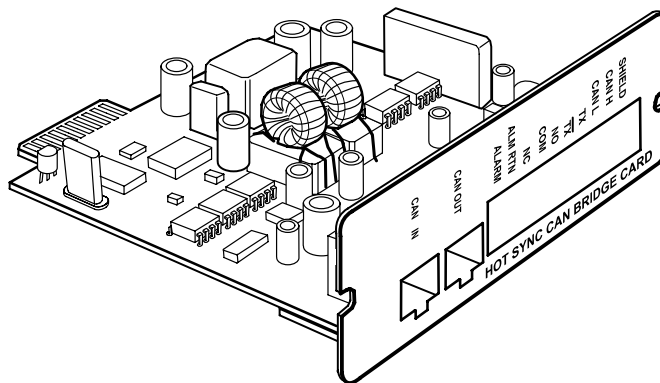

Figure 33. Powerware Hot Sync CAN Bridge Card



NOTE It is recommended to install the Powerware Hot Sync CAN Bridge Card in X-Slot Communication Bay 2 (see Figure 32 on page 49), leaving the X-Slot Communication Bay 1 available for other types of X-Slot cards.

5. Remove the X-Slot communication bay cover on the UPS and retain the screws.
6. Set the jumper pins on the Powerware Hot Sync CAN Bridge Card according to the parallel configuration (see Figure 34):
 - If only two UPSs are paralleled, then set both cards to Pins 1 and 2.
 - For three or more paralleled UPSs, set the cards of the first and last UPS to Pins 1 and 2; set the card for the middle UPS(s) to Pins 2 and 3.

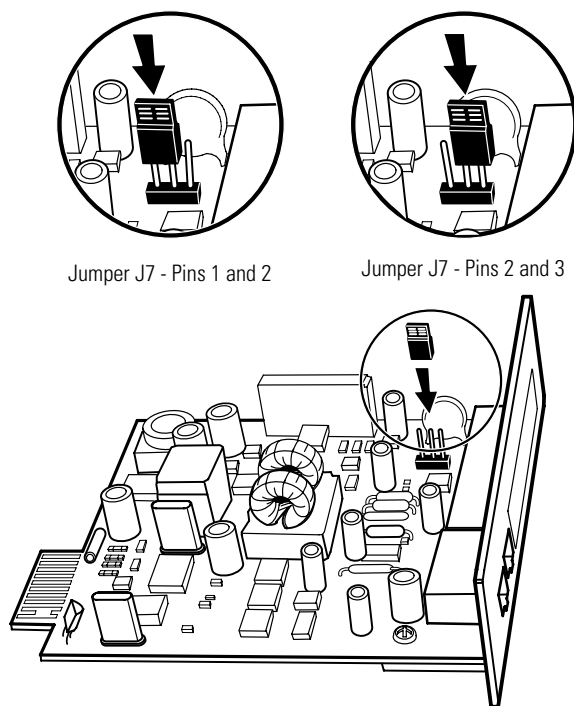

Figure 34. Setting the CAN Bridge Card Jumper J7 (Side View)

7. Loosely install the Powerware Hot Sync CAN Bridge Card into the open X-Slot on the UPS rear panel.
8. Repeat Steps 4 through 7 to install a CAN Bridge Card in each UPS to be paralleled.



NOTE The BladeUPS parallel system can automatically assign identities to each UPS in the system based on the order in which their CAN Bridge Cards are wired in Steps 9 and 10. For more information, see "Auto-Identification" on page 99.

9. Install the supplied initializing jumper (see Figure 35) into the CAN IN port on the first UPS (UPS 1 in Figure 36).

On startup, the parallel system will identify the UPS with the initializing jumper as UNIT 1.

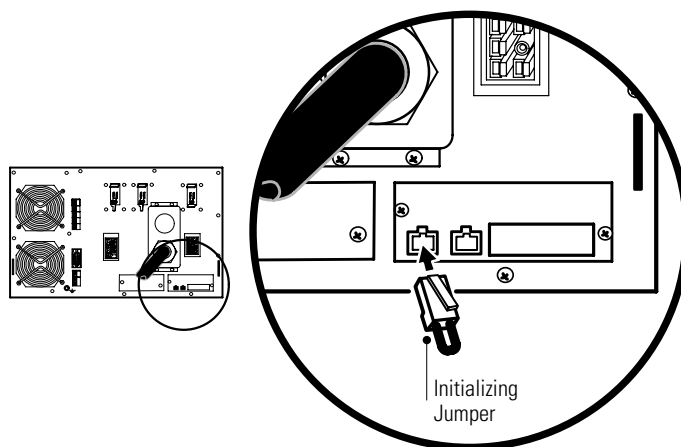

Figure 35. Installing the Initializing Jumper

10. Using the supplied connectors, install a CAN Bridge Card cable between each UPS as shown in Figure 36, connecting the CAN OUT port on one UPS to the CAN IN port on the next UPS.

On startup, the parallel system will identify the UPS wired after UNIT 1 as UNIT 2, and so forth.



NOTE You can configure the parallel system with UPS 1 at the bottom of the rack (as shown in Figure 36) or at the top of the rack.

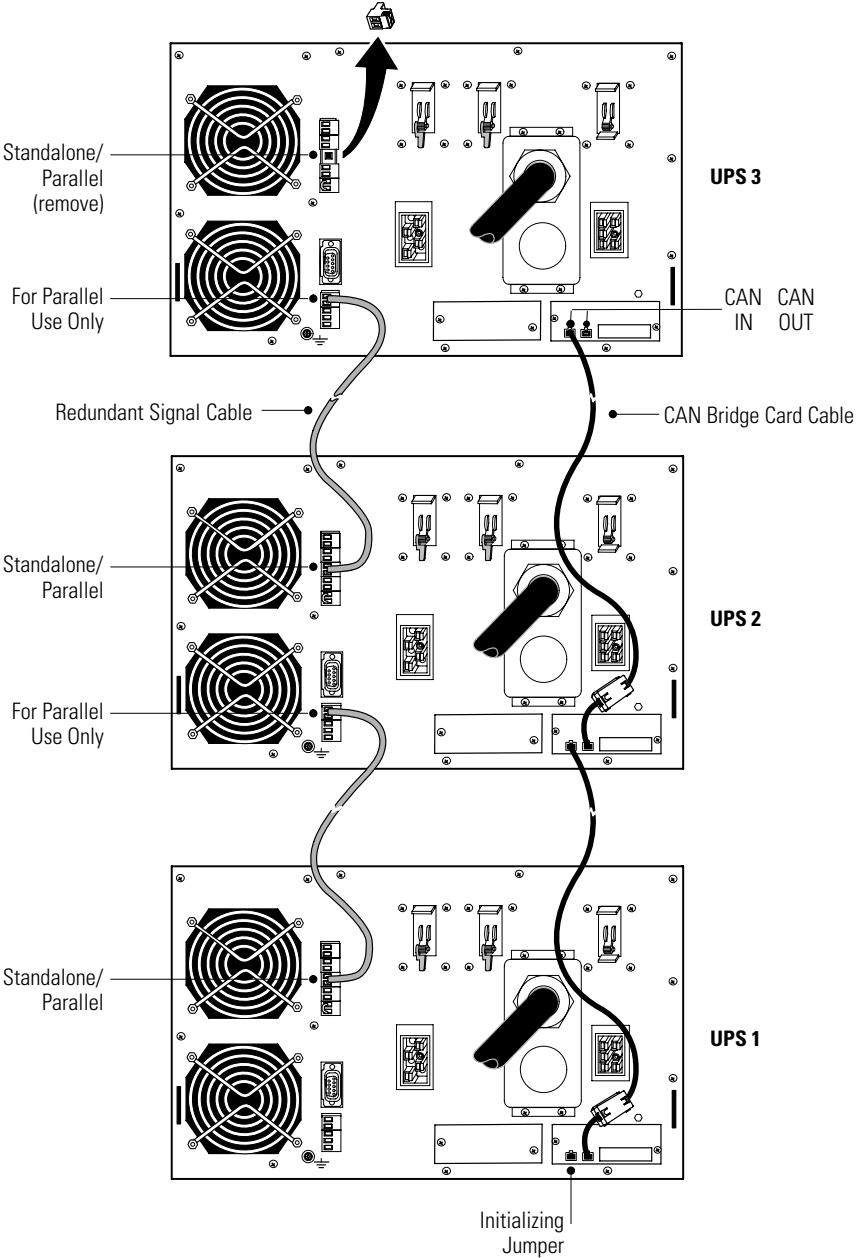

Figure 36. Typical CAN Bridge Card and Redundant Signal Wiring

11. Install a redundant signal cable between the For Parallel Use Only and Standalone/Parallel terminals on each UPS as shown in Figure 36. Remove the existing terminal block connectors before installing the cable.

Be sure to check correct polarity when installing the cable.

CAUTION



If polarity or wiring is not correct, the parallel system does not operate normally. For example, when shutting down one UPS, the remaining UPS transfers the load to bypass instead of supporting the load. Verify all wiring is correct for proper operation.

12. Remove the Standalone/Parallel terminal block connector from the last UPS (UPS 3 in Figure 36).
13. Tighten the screws securing each Powerware Hot Sync CAN Bridge Card in its X-Slot communication bay.
14. If you are installing power management software, connect your computer to the UPS communication port or optional X-Slot card (see page 89). For the communication port, use the supplied serial cable.



NOTE You may install one ConnectUPS™-X Web/SNMP Card per UPS, or one card per parallel system. Installing one card per UPS provides communication with each UPS. Installing one card per parallel system provides detection of a problem with at least one UPS, but does not specify which UPS or how many.

15. If you left the UPSs unattached to the rack, secure the front and rear of each UPS as described in Steps 14 and 15 on page 40.
16. If your rack has conductors for grounding or bonding of ungrounded metal parts, connect the ground cable (not included) to the ground bonding screw. See Figure 32 on page 49 for the location of the ground bonding screw.
17. You can install an optional REPO circuit that will shut down the entire parallel system using a single switch. See "Remote Emergency Power-off" on page 95 to install the REPO switch before powering on the parallel system.

18. Connect the parallel input cord from each paralleled UPS to the BladeUPS Bar in the rack as shown in Figure 37.

Gently loop and twist the parallel input cords as shown to minimize stress on the cords. The loop and twist for each cord may vary depending on configuration and strain relief.

19. Continue to "Parallel System Initial Startup" on page 68.

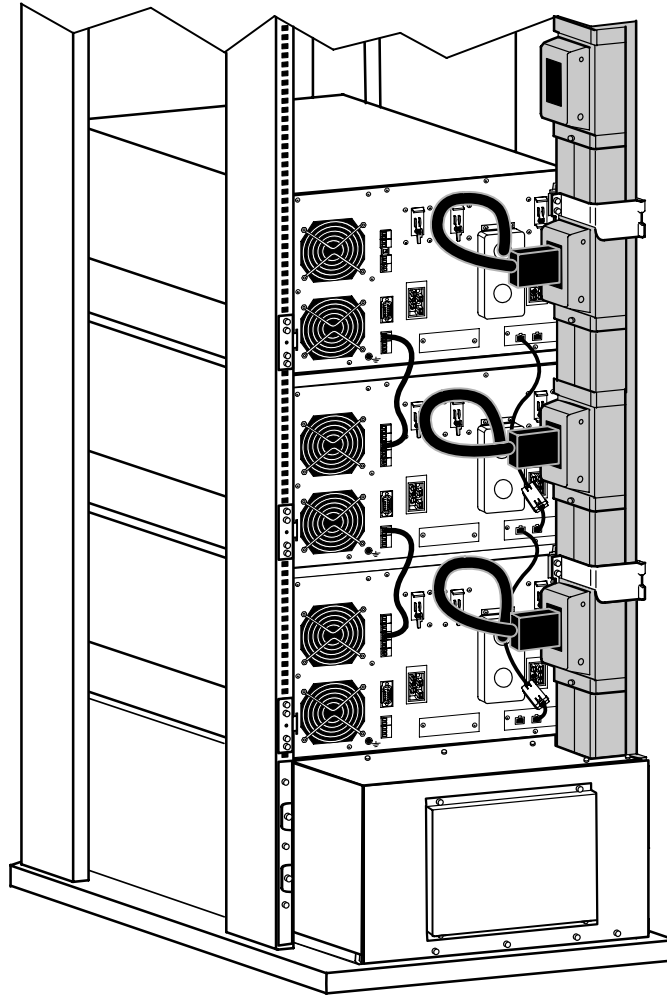
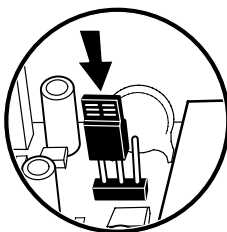

Figure 37. Connecting UPSs to the BladeUPS Bar (Bottom Entry Shown)



NOTE It is recommended to install the Powerware Hot Sync CAN Bridge Card in X-Slot Communication Bay 2 (see Figure 32 on page 49), leaving the X-Slot Communication Bay 1 available for other types of X-Slot cards.

5. Remove the X-Slot communication bay cover on the UPS and retain the screws.
6. Set the jumper pins on the Powerware Hot Sync CAN Bridge Card as shown in Figure 39:



Jumper J7 - Pins 1 and 2

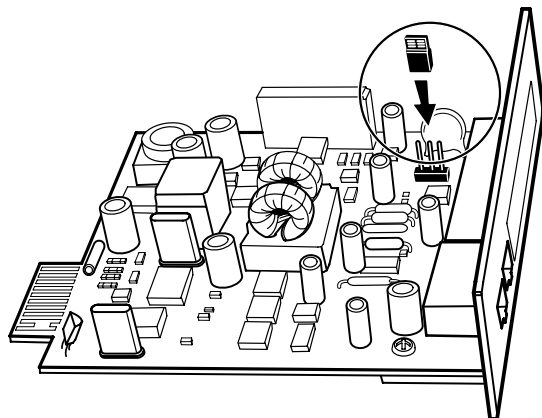

Figure 39. Setting the CAN Bridge Card Jumper J7 (Side View)

7. Loosely install the Powerware Hot Sync CAN Bridge Card into the open X-Slot on the UPS rear panel.
8. Install the supplied initializing jumper (see Figure 40) into the CAN IN port on the UPS.

On startup, the parallel-ready system will identify the UPS with the initializing jumper as UNIT 1.

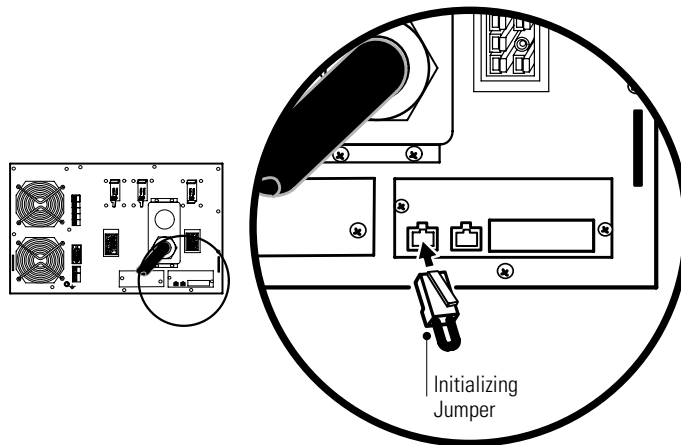

Figure 40. Installing the Initializing Jumper

9. Tighten the screws securing the Powerware Hot Sync CAN Bridge Card in its X-Slot communication bay.
10. If you are installing power management software, connect your computer to the UPS communication port or optional X-Slot card (see page 89). For the communication port, use the supplied serial cable.



NOTE You may install one ConnectUPS-X Web/SNMP Card per UPS, or one card per parallel system. Installing one card per UPS provides communication with each UPS. Installing one card per parallel system provides detection of a problem with at least one UPS, but does not specify which UPS or how many.

- 11.** If you left the UPS unattached to the rack, secure the front and rear of the UPS as described in Steps 14 and 15 on page 40.
- 12.** If your rack has conductors for grounding or bonding of ungrounded metal parts, connect the ground cable (not included) to the ground bonding screw. See Figure 32 on page 49 for the location of the ground bonding screw.
- 13.** You can install an optional REPO circuit that will shut down the entire parallel-ready system using a single switch. See “Remote Emergency Power-off” on page 95 to install the REPO switch before powering on the parallel-ready system.
- 14.** Connect the parallel input cord from the UPS to the BladeUPS Bar in the rack as shown in Figure 37 on page 55.

Gently loop and twist the parallel input cord as shown to minimize stress on the cord. The loop and twist for the cord may vary depending on configuration and strain relief.

- 15.** Continue to “Parallel System Initial Startup” on page 68.

UPS Installation into an Existing Parallel System

WARNING



Only qualified service personnel (such as a licensed electrician) shall perform the electrical installation. Risk of electrical shock.



NOTE Do not make unauthorized changes to the UPSs; otherwise, damage may occur to your equipment and void your warranty.

UPSs can be installed into an existing system without shutting down the system or disconnecting the load. If you prefer to remove input power to install additional UPSs, see “Parallel System Shutdown” on page 85.

To install one to five UPSs into an existing parallel (or parallel-ready) configuration:

1. Verify that the UPSs to be paralleled are installed in individual rail kits in a rack containing a BladeUPS Bar.
2. For each additional UPS being installed, verify that all circuit breakers are in the OFF (O) position.



NOTE The load connector breaker controls the load connector only, not the output power cord.

3. Unpack the Powerware Hot Sync CAN Bridge Card and verify that the card was not damaged during shipment (see Figure 41).

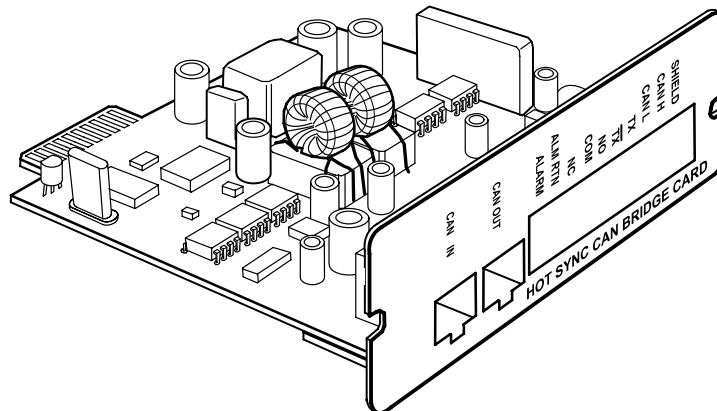

Figure 41. Powerware Hot Sync CAN Bridge Card



NOTE It is recommended to install the Powerware Hot Sync CAN Bridge Card in X-Slot Communication Bay 2 (see Figure 32 on page 49), leaving the X-Slot Communication Bay 1 available for other types of X-Slot cards.

- 4. Remove the X-Slot communication bay cover on the UPS and retain the screws.
- 5. Set the jumper pins on the Powerware Hot Sync CAN Bridge Card according to the parallel configuration (see Figure 42):
 - If only two UPSs are paralleled, then set both cards to Pins 1 and 2.
 - For three or more paralleled UPSs, set the cards of the first and last UPS to Pins 1 and 2; set the card for the middle UPS(s) to Pins 2 and 3.

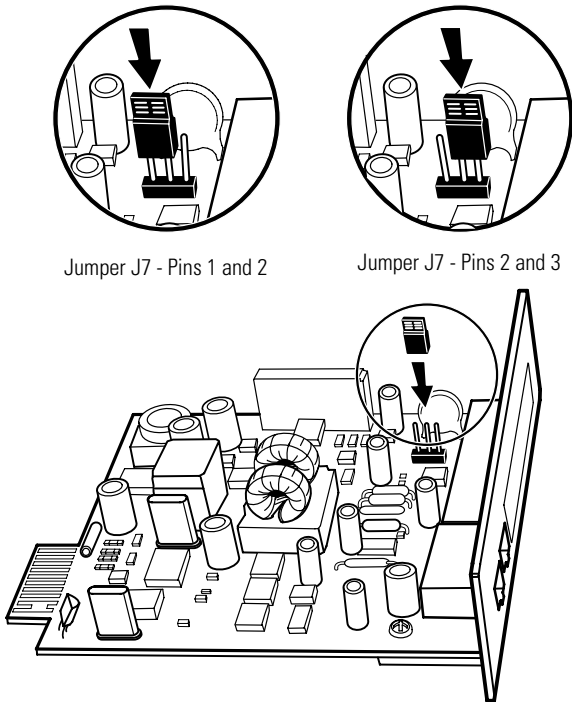

Figure 42. Setting the CAN Bridge Card Jumper J7 (Side View)

6. Loosely install the Powerware Hot Sync CAN Bridge Card into the open X-Slot on the UPS rear panel.
7. Repeat Steps 3 through 6 to install a CAN Bridge Card in each newly installed UPS to be paralleled.
8. Repeat Steps 4 through 6 to reset the jumper pins in each previously installed UPS to be paralleled. Depending on configuration, not all previously installed UPSs may need their jumper pins reset.

In a parallel system not previously shut down, the system will report various alarms until the CAN Bridge Cards are fully installed and connected.



NOTE *The BladeUPS parallel system can automatically assign identities to each UPS in the system based on the order in which their CAN Bridge Cards are wired in Steps 9 and 10. For more information, see "Auto-Identification" on page 99.*

9. Verify that the supplied initializing jumper is installed in the CAN IN port on the first UPS (UPS 1 in Figure 43).

On startup, the parallel system will identify the UPS with the initializing jumper as UNIT 1.

10. Using the supplied connectors, install a CAN Bridge Card cable between each UPS as shown in Figure 43, connecting the CAN OUT port on one UPS to the CAN IN port on the next UPS.

On startup, the parallel system will identify the UPS wired after UNIT 1 as UNIT 2, and so forth.



NOTE *You can configure the parallel system with UPS 1 at the bottom of the rack (as shown in Figure 43) or at the top of the rack.*

11. For a parallel system not previously shut down, verify that any alarms related to reconfiguring the CAN Bridge Cards have cleared.

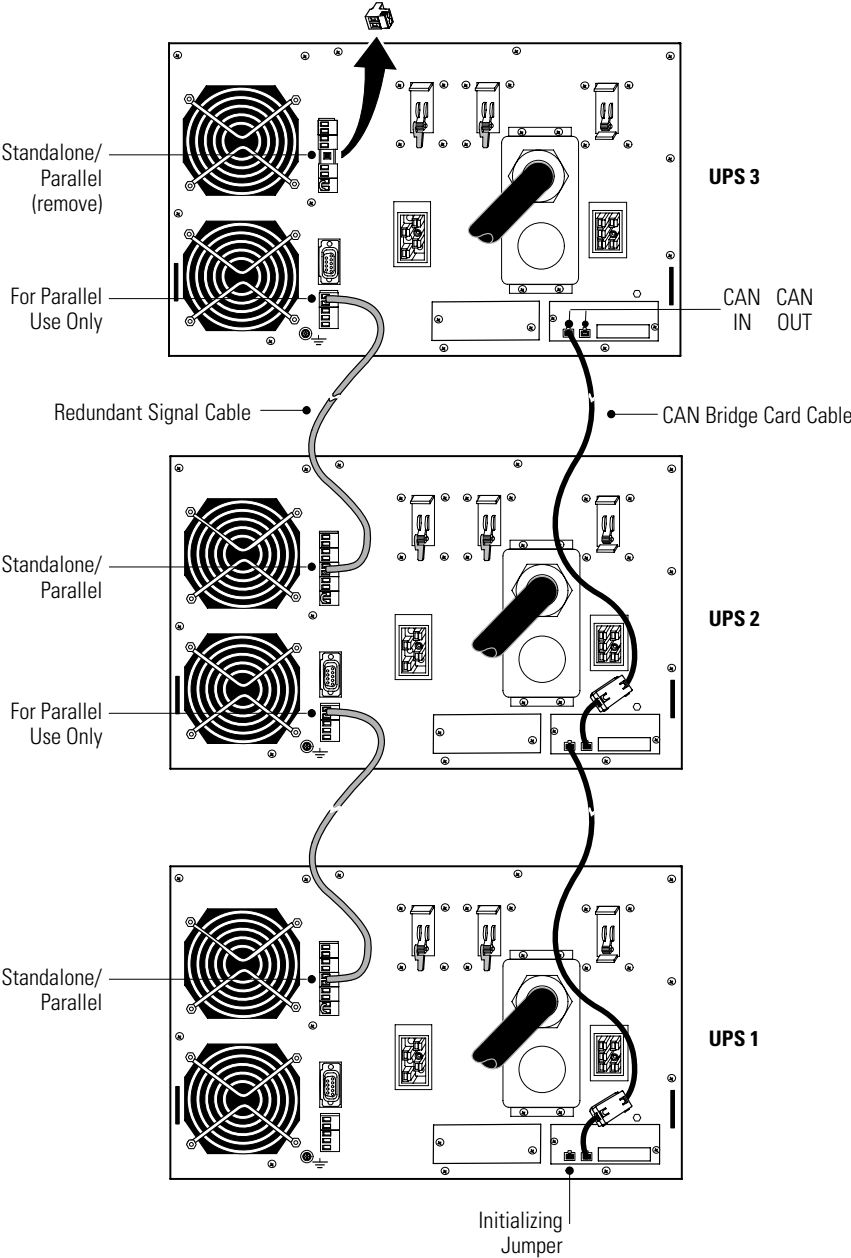

Figure 43. Typical CAN Bridge Card and Redundant Signal Wiring

12. Install a redundant signal cable between the For Parallel Use Only and Standalone/Parallel terminals on each UPS as shown in Figure 43. Remove the existing terminal block connectors before installing the cable.

Be sure to check correct polarity when installing the cable.



CAUTION

If polarity or wiring is not correct, the parallel system does not operate normally. For example, when shutting down one UPS, the remaining UPS transfers the load to bypass instead of supporting the load. Verify all wiring is correct for proper operation.

13. Remove the Standalone/Parallel terminal block connector from the last UPS (UPS 3 in Figure 43).
14. Tighten the screws securing each Powerware Hot Sync CAN Bridge Card in its X-Slot communication bay.
15. If you are installing power management software, connect your computer to the UPS communication port or optional X-Slot card (see page 89). For the communication port, use the supplied serial cable.



NOTE You may install one ConnectUPS-X Web/SNMP Card per UPS, or one card per parallel system. Installing one card per UPS provides communication with each UPS. Installing one card per parallel system provides detection of a problem with at least one UPS, but does not specify which UPS or how many.

16. If you left the UPSs unattached to the rack, secure the front and rear of each UPS as described in Steps 14 and 15 on page 40.
17. If your rack has conductors for grounding or bonding of ungrounded metal parts, connect the ground cable (not included) to the ground bonding screw. See Figure 32 on page 49 for the location of the ground bonding screw.
18. You can install an optional REPO circuit that will shut down the entire parallel system using a single switch. See "Remote Emergency Power-off" on page 95 to install the REPO switch before powering on the parallel system.

19. Connect the parallel input cord from each paralleled UPS to the BladeUPS Bar in the rack as shown in Figure 44.

Gently loop and twist the parallel input cords as shown to minimize stress on the cords. The loop and twist for each cord may vary depending on configuration and strain relief.

20. Continue to "Parallel System Initial Startup" on page 68. If you installed the additional UPS(s) without shutting down the parallel system, perform the steps in "Parallel System Initial Startup" on the additional UPS(s) only.

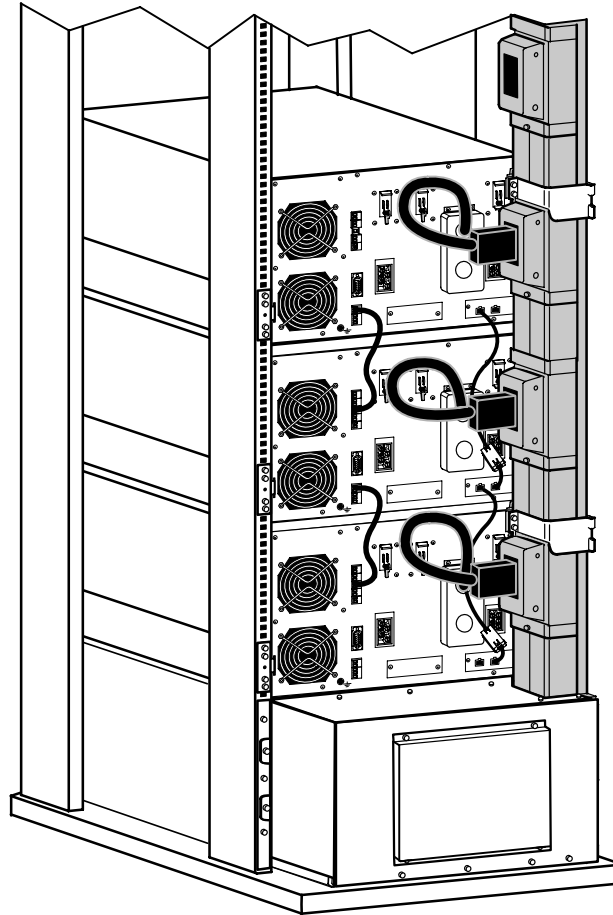

Figure 44. Connecting UPSs to the BladeUPS Bar (Bottom Entry Shown)

Standalone UPS Initial Startup

To start up a standalone UPS:





NOTE Verify that the total equipment ratings do not exceed the UPS capacity to prevent an overload alarm.

1. Plug the equipment to be protected into the UPS, but do not turn on the protected equipment (see Figure 32 on page 49).
2. Make any necessary provisions for cord retention and strain relief.
3. Verify that all UPS circuit breakers are in the OFF (O) position.





NOTE The load connector breaker controls the load connector only, not the output power cord.

4. Verify that the UPS power cord is plugged in.
5. Switch on utility power where the UPS is connected.
6. Remove the breaker ties from the circuit breakers.
7. Switch the UPS input circuit breaker to the ON (|) position.
8. Wait for the UPS front panel display to illuminate.
The  indicator flashes on the UPS.
9. Check the UPS front panel display for active alarms or notices (other than “Batteries Disconnected”). Resolve any active alarms before continuing. See “Troubleshooting” on page 119.
10. Switch the UPS battery circuit breaker to the ON (|) position.
11. If optional EBMs are installed, switch all EBM battery circuit breakers to the ON (|) position.
12. Verify that the “Batteries Disconnected” alarm has cleared. Verify that no other alarms appear on the UPS front panel display.

If the  indicator is flashing, do not proceed until all alarms are clear. Check the UPS status from the front panel to view the active alarms. Correct the alarms and restart if necessary.

13. Press any button on the front panel display to activate the menu options, and then press the ↓ button until the TURN UPS ON/OFF menu displays.
14. Press the → button to display the TURN UPS ON option; press the ← button.
15. Confirm the selection. Press and hold the ← button for three seconds, until the UPS stops beeping.

Verify that the  indicator illuminates solid, indicating that the UPS is operating normally and any loads not connected through the load connector are now energized.

If the  indicator is flashing, do not proceed until all alarms are clear. Check the UPS status from the front panel to view the active alarms. Correct the alarms and restart if necessary.

The UPS should be in Normal mode. By default, Normal mode operates on the High Efficiency setting (see “Normal Mode” on page 76).

16. To energize a load connected through the load connector, switch the load connector circuit breaker to the ON (|) position.
17. Press the  button until the Eaton Powerware logo appears.
18. If optional EBMs are installed, see “Configuring the UPS for EBMs” on page 87 to set the number of installed EBMs.
19. To change any other factory-set defaults, see “Operation” on page 71.



NOTE *It is recommended to set the Date and Time and the Start Screen.*

20. If you installed an optional REPO, test the REPO function:

Activate the external REPO switch. Verify the status change on the UPS display.

Deactivate the external REPO switch and restart the UPS.



NOTE *The batteries charge to 80% capacity in less than 5 hours. However, it is recommended that the batteries charge for 48 hours after installation or long-term storage.*

21. See “Updating the UPS Firmware” on page 112.

Parallel System Initial Startup

To start up a parallel (or parallel-ready) system:



NOTE *Verify that the total equipment ratings do not exceed the parallel system capacity to prevent an overload alarm.*

1. Verify that all UPS circuit breakers are in the OFF (O) position.



NOTE *The load connector breaker controls the load connector only, not the output power cord.*

2. Switch on utility power where the UPS is connected.
3. Remove the breaker ties from the circuit breakers.
4. Switch the UPS input circuit breaker on each UPS to the ON (|) position.
5. Wait for the front panel display on each UPS to illuminate.

The  indicator flashes on each UPS.

6. Check each UPS front panel display for active alarms or notices (other than “Batteries Disconnected”). Resolve any active alarms before continuing. See “Troubleshooting” on page 119.
7. Switch all UPS battery circuit breakers to the ON (|) position.
8. If optional EBMs are installed, switch all EBM battery circuit breakers to the ON (|) position.

9. Verify that the “Batteries Disconnected” alarm on each UPS has cleared. Verify that no other alarms appear on any UPS front panel display.

If an  indicator is flashing on any UPS, do not proceed until all alarms are clear. Check the UPS status from the front panel to view the active alarms. Correct the alarms and restart if necessary.

10. On any UPS, press any button on the front panel display to activate the menu options, and then press the ↓ button until the TURN UPS ON/OFF menu displays.
11. Press the → button to display the TURN SYSTEM ON option; press the ← button.
12. Confirm the selection. Press and hold the ← button for three seconds, until the UPS stops beeping.

Verify that the  indicator illuminates solid on each UPS, indicating that the UPS is operating normally and any loads not connected through the load connector are now energized.

If the  indicator on any UPS is flashing, do not proceed until all alarms are clear. Check the UPS status from the front panel to view the active alarms. Correct the alarms and restart if necessary.

Each UPS should be in Normal mode. By default, Normal mode operates on the High Efficiency setting (see “Normal Mode” on page 76).

13. To energize loads connected through the load connectors, switch all load connector circuit breakers to the ON (|) position.
14. On any UPS, press the  button until the Eaton Powerware logo appears.
15. If optional EBMs are installed, see “Configuring the UPS for EBMs” on page 87 to set the number of installed EBMs for each UPS.

16. To change any other factory-set defaults, see “Operation” on page 71.



NOTE *It is recommended to set the Date and Time and the Start Screen.*

NOTE *Verify that the Parallel Operation Settings are set appropriately for your system. For example, if you know the load will exceed the redundancy level of the system, set the Parallel Operation Mode to “Capacity Mode” to prevent unnecessary alarms.*

NOTE *For a parallel-ready system (a single UPS installed to be part of a future parallel system), set the Parallel Operation Settings / Parallel Operation Mode to “Capacity Mode” to prevent unnecessary alarms.*

17. If you installed an optional REPO, test the REPO function:

Activate the external REPO switch. Verify the status change on the UPS display.

Deactivate the external REPO switch and restart the UPS.



NOTE *The batteries charge to 80% capacity in less than 5 hours. However, it is recommended that the batteries charge for 48 hours after installation or long-term storage.*

18. See “Updating the UPS Firmware” on page 112.



NOTE *When adding a new UPS to a parallel system or updating one UPS’s firmware, verify that all UPSs in the parallel system are updated to the same firmware version.*

Chapter 4 Operation

This chapter contains information on how to use the BladeUPS, including front panel operation, operating modes, UPS startup and shutdown, configuring the UPS for Extended Battery Modules (EBMs), transferring the UPS between modes, and setting the power strategy.

Control Panel Functions

The UPS has a four-button graphical LCD with backlight. It provides useful information about the UPS itself, load status, events, measurements, and settings (see Figure 45).

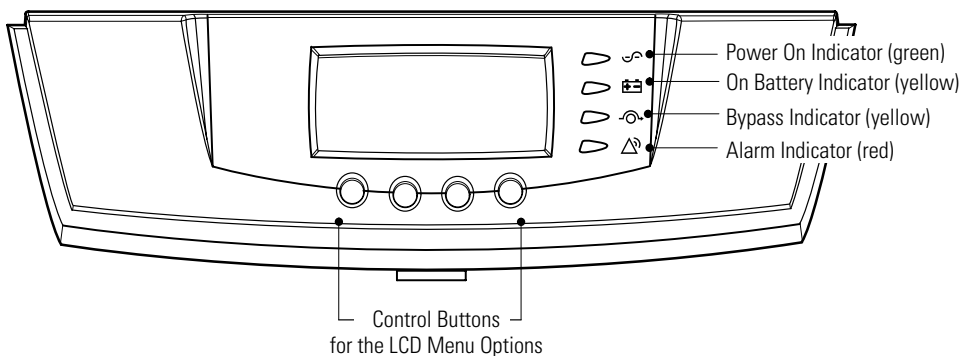

Figure 45. BladeUPS Control Panel

The Mimic screen shows the internal components of the UPS and a real-time display of the operating status (see Figure 46). A thicker bar indicates the node is energized.

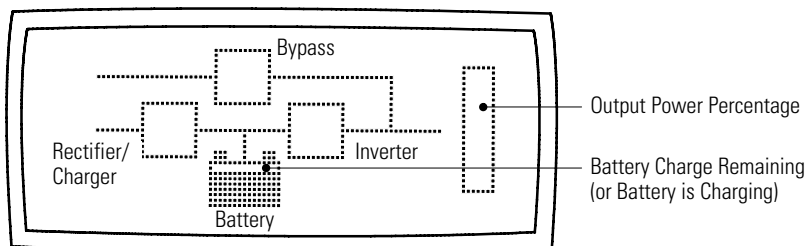





Figure 46. BladeUPS Mimic Screen

The following table shows the indicator status and description.

Indicator	Status	Description
	On	The UPS is operating normally.
Green	Flashing	<ul style="list-style-type: none"> The UPS is starting up or is shut down and waiting for power to return. A new information message is active. Bypass is not available.
	Off	The UPS is turned off and will not turn on automatically.
	On	The UPS is in Battery mode.
Yellow		
	On	The UPS is in Bypass mode.
Yellow		
	On	The UPS has an active alarm.
Red	Flashing	There is a new UPS alarm condition. See "Troubleshooting" on page 119 for additional information.

Changing the Language

Press and hold the first button on the left for approximately five seconds to select the language menu. This action is possible from any LCD menu screen.

Display Functions

As the default or after 15 minutes of inactivity, the LCD displays the selectable startup screen. The default is the Eaton Powerware logo and can be changed to the Mimic screen in the User Settings menu.

The backlit LCD automatically dims after a long period of inactivity. Press any button to restore the screen.

Press any button to activate the menu options. Use the two middle buttons (↑ and ↓) to scroll through the menu structure. Press the → button to enter a submenu. Press the ← button to select an option. Press the **ESC** button to cancel or return to the previous menu.

The following table shows the basic menu structure.



NOTE Menu functions related to parallel systems appear only on paralleled UPSs.

Table 3. Menu Map for Display Functions

Main Menu	Submenu	Display Information or Menu Function
UPS Status		System Normal High Efficiency Power: % / Battery Resting Battery Floating UPS in Parallel mode / Parallel Unit Number x / Units on CAN Bus / Units on Load
Event Log		Displays up to 100 events and alarms
Measurements For more information about measurements, see "Metering" on page 99.	Parallel System	kW [by unit] / kW [Parallel total]
	Output	Voltage L-N and L-L / Current / Frequency / Power kW / Power kVA / Power pf
	Battery	Voltage / Current / Runtime
	Input	Voltage L-N and L-L / Current / Frequency
	Load Receptacle	Voltage / Current / Power kW / Power kVA / Frequency
Control	Go to Bypass Mode	Transfers the UPS system to internal Bypass mode When this command is active, the option changes to Go to Normal Mode.
	Start Battery Test	Initiates a battery test
	Display Test	Four different selectable tests for the front panel functions: the LEDs cycle through, the alarm beep sounds, the backlight turns off and on, and the pixels scroll through to test the LCD.
Settings	User Settings	See Table 4 for detail.
	Service Settings	Not available.
Identification		UPS Type / Part Number / Serial Number / Firmware / Display / System Display / CAN Bridge
Turn UPS On/Off	On and Off Options	UPS On / UPS Off / System On / System Off

User Settings

The following table displays the options that can be changed by the user.

Table 4. User Settings

Description	Available Settings	Default Setting
Set Date and Time	Set Year, Month, Day Date: mm/dd/yyyy Set Hours, Minutes Time is a 24-hour clock.	01/01/2003 00:00
Display Contrast	Adjust contrast with up/down arrow buttons	Moderate
Change Language	Select Language Available languages depend on model and languages installed.	English
Relay Config	Relay: [Alarm-1] [X-Slot 1-1/2/3/4] or [X-Slot 2-1/2/3/4] Setup: [On Battery] [Summary Alarm] [On Bypass] [UPS OK] [custom] [empty]	Alarm 1: empty X-Slots (1 or 2) #1: UPS OK #2: On Bypass #3: Summary Alarm #4: On Battery
Signal Inputs	Signal: [X-Slot-1] [X-Slot-2] [INPUT 1] [INPUT 2] [signal inputs] Logic: [0] [1] For more information, see "Programmable Signal Inputs" on page 97.	<empty> [1]
Serial Port Config	Port: [X-Slot-1] [X-Slot-2/Serv] Speed: [19200] [9600] [2400] [1200]	19200
Parallel Operation Settings	System Display Subunit: [Unit #1...6] Selects which unit the System display communicates with.	Unit #1
	Parallel Operation Mode: [Redundant Mode] [Capacity Mode] This setting is not available for six-unit systems (must be Redundant Mode only).	Redundant Mode
	Parallel XCP: [System] [Sub Unit] Select Sub Unit for PowerVision software. Select System for other software.	System

Table 4. User Settings (continued)

Description	Available Settings	Default Setting
Modem Config	Modem Installation: [Not Installed] [X-Slot-1] [X-Slot-2]	Not Installed
	Set Modem Call Events	Event #0 Call modem: no
	Set Modem Init String	ATZ0
	Set Modem Call Command	None
	Set Modem Communication Password	None
Battery Setup	Number of ERMs: [0 through 4] (see “Configuring the UPS for EBMs” on page 87)	0 (means internal batteries only)
	Battery Low Alarm Level: [1.750 through 1.950 volts per cell] (see “Setting the Battery Low Alarm Level” on page 88)	1.880 V/cell (provides approximately 2.5 min warning for the UPS)
	Automatic Battery Tests: [Enabled] [Disabled] (see “Running Automatic Battery Tests” on page 87)	Enabled (automatically runs the battery test once a month)
Power Strategy	[High Efficiency] [Standard] The Standard setting is limited to 60 minutes when selected through the front panel. See the following section, “Operating Modes.”	High Efficiency
Start Screen	Eaton Powerware logo Mimic screen (see Figure 46 on page 71)	Eaton Powerware logo
User Password	[Enabled] [Disabled] If Enabled is selected, the password is USER.	Disabled
Audible Alarms	[Normal Sound] [Disabled]	Normal Sound
Unsynchronized Transfer to Bypass	[Allowed] [Not Allowed]	Not Allowed
Transfer to Bypass When Overload	[After a delay] [Immediately]	After a delay
Automatic Start Delay	-1 through 32767 seconds (-1 means disabled)	0s
Control Commands from X-Slot1	[Allowed] [Not Allowed] Selecting Not Allowed prevents load commands such as Load Off through the X-Slot, including remotely.	Allowed
Control Commands from X-Slot2/Serv		
X-Slot Signal Input Activation Delay	0 through 65 seconds	5s

Table 4. User Settings (continued)

Description	Available Settings	Default Setting
Site Wiring Fault Notice	[Enabled] [Disabled]	Enabled
Input Range	[Standard] [Reduced]* Use this setting to select the Standard curve or the Reduced curve for the output voltage range (see Table 13 on page 116). The Reduced curve is similar to the Information Technology Industry Council (ITIC) curve.	Standard * The choice of Standard or Reduced is available on the BladeUPS 12 model only. The BladeUPS 12i model by default uses the Reduced curve as its Standard setting.
Reset Custom Event Settings	0 through 32	Total: 0/32
REPO Configuration	[Enabled][Disabled]	Enabled

Operating Modes

The BladeUPS front panel indicates the UPS status through the UPS indicators. Figure 45 on page 71 shows the UPS front panel indicators and controls.

Normal Mode

During Normal mode, the  indicator illuminates solid and the UPS is powered from the utility. The UPS monitors and charges the batteries as needed and provides filtered power protection to your equipment.

By default, the BladeUPS operates on a High Efficiency setting that minimizes heat contribution to the rack environment. The system bypass input directly supplies the system output with three-phase AC power, and the UPS stands ready to automatically transfer to double-conversion (Standard) operation as needed. The battery recharges when necessary.



If the input line exceeds normal operating range, the UPS transfers to Standard operation to produce a regulated output voltage. When the input line returns to normal operating range, the UPS returns to High Efficiency operation.

You can change the default High Efficiency setting to Standard from the front panel. The Standard setting disables the High Efficiency feature for a maximum of 60 minutes. See “User Settings” on page 74.

Battery Mode

When the UPS is operating during a power outage, the alarm beeps once every five seconds and the  indicator illuminates solid.

When the utility power returns, the UPS transfers to Normal mode operation while the battery recharges.

If battery capacity becomes low while in Battery mode, the  indicator flashes slowly and the audible alarm becomes continuous. If the Battery Low alarm is set, the  indicator also illuminates solid. This warning is approximate, and the actual time to shutdown may vary significantly.



NOTE Depending on the UPS load and the number of Extended Battery Modules (EBMs), the Battery Low warning may occur before the batteries reach 25% capacity. See Table 16 on page 118 for estimated runtimes.

When utility power is restored after the UPS shuts down, the UPS automatically restarts.

Bypass Mode

In the event of a UPS overload or internal failure, the UPS transfers your equipment to utility power. Battery mode is not available and your equipment is not protected; however, the utility power continues to be passively filtered by the UPS. The  indicator illuminates.

The UPS transfers to Bypass mode when:

- The user activates Bypass mode through the front panel.
- The UPS detects the control panel being disconnected from the electronics module.
- The UPS detects the electronics module being replaced.
- The UPS detects an internal failure.
- The UPS has an overtemperature condition.
- The UPS has an overload condition listed in Table 13 on page 116.

Standby Mode

When the UPS is turned off and remains plugged into a power outlet, the UPS is in Standby mode. The  indicator is off, indicating that power is not available to your equipment. The battery recharges when necessary.

UPS Startup and Shutdown

To start up or shut down a UPS, see:

- “Starting a Standalone UPS” on page 78
- “Starting a Parallel System” on page 80
- “Starting the UPS on Internal Bypass” on page 81
- “Standalone UPS Shutdown” on page 83
- “Individual Paralleled UPS Shutdown” on page 84
- “Parallel System Shutdown” on page 85

Starting a Standalone UPS

To start a standalone UPS (see Figure 32 on page 49):

1. Verify that all UPS circuit breakers are in the OFF (O) position.





NOTE *The load connector breaker controls the load connector only, not the output power.*

2. Verify that the UPS power cord is plugged in.
3. Switch on utility power where the UPS is connected.
4. Switch the UPS input circuit breaker to the ON (|) position.
5. Wait for the UPS front panel display to illuminate.
The  indicator flashes on the UPS.
6. Check the UPS front panel display for active alarms or notices (other than “Batteries Disconnected”). Resolve any active alarms before continuing. See “Troubleshooting” on page 119.
7. Switch the UPS battery circuit breaker to the ON (|) position.
8. If optional EBMs are installed, switch all EBM battery circuit breakers to the ON (|) position.

9. Verify that the “Batteries Disconnected” alarm has cleared. Verify that no other alarms appear on the UPS front panel display.

If the  indicator is flashing, do not proceed until all alarms are clear. Check the UPS status from the front panel to view the active alarms. Correct the alarms and restart if necessary.

10. Press any button on the front panel display to activate the menu options. Select TURN UPS ON/OFF, TURN UPS ON, and press the  button.
11. Confirm the selection. Press and hold the  button for three seconds, until the UPS stops beeping.

Verify that the  indicator illuminates solid, indicating that the UPS is operating normally and any loads not connected through the Load Connector are now energized.

If the  indicator is flashing, do not proceed until all alarms are clear. Check the UPS status from the front panel to view the active alarms. Correct the alarms and restart if necessary.

The UPS should be in Normal mode. By default, Normal mode operates on the High Efficiency setting (see “Normal Mode” on page 76).

12. To energize a load connected through the Load Connector, switch the load connector circuit breaker to the ON (|) position.
13. Press the  button until the Eaton Powerware logo appears.

Starting a Parallel System

To start a parallel system (see Figure 32 on page 49):

1. Verify that all UPS circuit breakers are in the OFF (O) position.





NOTE *The load connector breaker controls the load connector only, not the output power.*

2. Verify that all UPS power cords are plugged in.
3. Verify that all redundant signal cables are connected.
4. Switch on utility power where the UPSs are connected.
5. Switch the UPS input circuit breakers on each UPS to the ON (|) position.
6. Wait for the front panel display on each UPS to illuminate.

The  indicator flashes on each UPS.

7. Check each UPS front panel display for active alarms or notices (other than “Batteries Disconnected”). Resolve any active alarms before continuing. See “Troubleshooting” on page 119.
8. Switch all UPS battery circuit breakers to the ON (|) position.
9. If optional EBMs are installed, switch all EBM battery circuit breakers to the ON (|) position.
10. Verify that the “Batteries Disconnected” alarm on each UPS has cleared. Verify that no other alarms appear on any UPS front panel display.

If the  indicator is flashing on any UPS, do not proceed until all alarms are clear. Check the UPS status from the front panel to view the active alarms. Correct the alarms and restart if necessary.

11. On any UPS, press any button on the front panel display to activate the menu options. Select TURN UPS ON/OFF, TURN SYSTEM ON, and press the  button.

12. Confirm the selection. Press and hold the  button for three seconds, until the UPS stops beeping.

Verify that the  indicator illuminates solid on each UPS, indicating that the UPS is operating normally and any loads not connected through the Load Connector are now energized.

If the  indicator on any UPS is flashing, do not proceed until all alarms are clear. Check the UPS status from the front panel to view the active alarms. Correct the alarms and restart if necessary.

Each UPS should be in Normal mode. By default, Normal mode operates on the High Efficiency setting (see “Normal Mode” on page 76).

13. To energize loads connected through the Load Connectors, switch all load connector circuit breakers to the ON (|) position.
14. On any UPS, press the  button until the Eaton Powerware logo appears.

Starting the UPS on Internal Bypass



NOTE Starting the UPS on internal bypass leaves the load unprotected.

To start a standalone UPS on internal bypass (see Figure 32 on page 49):

1. Verify that all UPS circuit breakers are in the OFF (O) position.



NOTE The load connector breaker controls the load connector only, not the output power.



2. Verify that the UPS power cord is plugged in.
3. Switch on utility power where the UPS is connected.
4. Switch the UPS input circuit breaker to the ON (|) position.
5. Wait for the UPS front panel display to illuminate.

The  indicator flashes on the UPS.

6. Check the UPS front panel display for active alarms or notices (other than “Batteries Disconnected”). Resolve any active alarms before continuing. See “Troubleshooting” on page 119.
7. Switch the UPS battery circuit breaker to the ON (|) position.
8. If optional EBMs are installed, switch all EBM battery circuit breakers to the ON (|) position.
9. Verify that the “Batteries Disconnected” alarm has cleared. Verify that no other alarms appear on the UPS front panel display.

If the  indicator is flashing, do not proceed until all alarms are clear. Check the UPS status from the front panel to view the active alarms. Correct the alarms and restart if necessary.

10. Press any button on the front panel display to activate the menu options. Select CONTROL and GO TO BYPASS MODE.

The  indicator illuminates solid and the  indicator flashes, indicating the UPS is operating in Bypass mode. The load is now powered by utility power.

If the  indicator is flashing, do not proceed until all alarms are clear. Check the UPS status from the front panel to view the active alarms. Correct the alarms and restart if necessary.

11. Switch the load connector circuit breaker to the ON (|) position.
12. Press the  button until the Eaton Powerware logo appears.

Standalone UPS Shutdown

To shut down a standalone UPS (see Figure 32 on page 49):

1. Switch the load connector circuit breaker to the OFF (O) position.



NOTE *The load connector breaker controls the load connector only, not the output power.*

2. Press any button on the front panel display to activate the menu options. Select TURN UPS ON/OFF, TURN UPS OFF, and press the \leftarrow button.
3. Confirm the selection. Press and hold the \leftarrow button for three seconds, until the UPS stops beeping.

The output relays open, the UPS transfers to Standby mode, and the  indicator turns off.

4. Switch the UPS battery circuit breaker to the OFF (O) position.
5. If optional EBMs are installed, switch all EBM battery circuit breakers to the OFF (O) position.
6. Switch the UPS input circuit breaker to the OFF (O) position.
7. Press the **ESC** button until the Eaton Powerware logo appears.
8. Switch off utility power where the UPS is connected.

Individual Paralleled UPS Shutdown

To shut down an individual UPS in the parallel system (see Figure 32 on page 49):

1. Switch the load connector circuit breaker to the OFF (O) position.



NOTE *The load connector breaker controls the load connector only, not the output power.*

2. Press any button on the front panel display to activate the menu options. Select TURN UPS ON/OFF, TURN UPS OFF, and press the \leftarrow button.
3. Confirm the selection. Press and hold the \leftarrow button for three seconds, until the UPS stops beeping.

The output relays open, the UPS transfers to Standby mode, and the  indicator turns off.

4. Switch the UPS battery circuit breaker to the OFF (O) position.
5. If optional EBMs are installed, switch all EBM battery circuit breakers to the OFF (O) position.
6. Switch the UPS input circuit breaker to the OFF (O) position.
7. Disconnect the redundant signal cable(s) from the UPS.
8. Press the **ESC** button until the Eaton Powerware logo appears.



NOTE *If there is only one breaker for all UPSs, do not switch off utility power until all UPSs are shut down.*

9. Switch off utility power where the UPS is connected.

If you are shutting down all the UPSs in a parallel system, repeat Steps 1 through 8 for each UPS then remove utility power.

Parallel System Shutdown

To remove power to the parallel UPS system output (see Figure 32 on page 49):

1. Switch one UPS load connector circuit breaker to the OFF (O) position.



NOTE *The load connector breaker controls the load connector only, not the output power.*

2. Press any button on the front panel display to activate the menu options. Select TURN UPS ON/OFF, TURN SYSTEM OFF, and press the ← button.
3. Confirm the selection. Press and hold the ← button for three seconds, until the UPS stops beeping.

The UPS removes power to the parallel UPS system output.

The output relays open, the UPSs transfer to Standby mode, and the  indicators turn off.

4. Switch the UPS battery circuit breaker to the OFF (O) position.
5. If optional EBMs are installed, switch all EBM battery circuit breakers to the OFF (O) position.
6. Switch the UPS input circuit breaker to the OFF (O) position.
7. Press the  button until the Eaton Powerware logo appears.
8. If you want to completely remove power from the UPSs, continue to “Standalone UPS Shutdown” on page 83 to shut down each individual UPS.

Transferring the UPS Between Modes

From Normal to Bypass Mode. Press any button to activate the menu options, then select CONTROL and GO TO BYPASS MODE.

From Bypass to Normal Mode. Press any button to activate the menu options, then select CONTROL and GO TO NORMAL MODE.
Alternatively (standalone UPS only): Press any button to activate the menu options, then select TURN UPS ON/OFF, TURN UPS ON, and OK to confirm.

Setting Power Strategy

To set the power strategy:

1. Press any button to activate the menu options, then select SETTINGS, USER SETTINGS, and POWER STRATEGY.
2. Select HIGH EFFICIENCY or STANDARD, and OK to confirm.



NOTE Time in the Standard power strategy is limited to 60 minutes when commanded through the front panel. The setting then automatically returns to High Efficiency.

Configuring Battery Settings

Set the UPS for the number of EBMs installed, whether to run automatic battery tests, and the level for the Battery Low alarm.

Configuring the UPS for EBMs

To ensure maximum battery runtime, configure the UPS for the correct number of EBMs:

1. Press any button on the front panel display to activate the menu options, then select SETTINGS, USER SETTINGS, BATTERY SETUP, and NUMBER OF EBMs.
2. Use the ↑ or ↓ buttons to select the number of EBMs according to your UPS configuration:

All UPS and EBM Cabinets	Number of EBMs
UPS only	0 (default)
UPS + 1 EBM	1
UPS + 2 EBMs	2
UPS + 3 EBMs	3
UPS + 4 EBMs	4

3. Press the ← button to save the setting.
4. Press the **ESC** button until the Eaton Powerware logo appears.

Running Automatic Battery Tests

Battery tests rely on backfeeding the utility, using the utility as a load. Some sites may choose to disable battery testing if their source is not capable of being backfed. Examples of such sources include generators, other UPSs, and other stiff or soft sources.

If a test is run on a source not capable of being backfed, the BladeUPS will abort the test (due to utility failure) and will maintain the load and log the event. Further consequences depend on the source (for example, another UPS feeding the BladeUPS may trip off).

Setting the Battery Low Alarm Level

The default Battery Low Alarm Level setting provides approximately 2.5 minutes of battery warning for a UPS. Additional EBMs installed in a parallel system can provide a longer warning time. To adjust the Battery Low Alarm Level setting to provide different warning times for a parallel system with additional EBMs installed, see Table 5.

Table 5. Suggested Battery Low Alarm Level Settings

Warning Time (in Minutes)	Number of EBMs Installed	Battery Low Alarm Level (User Setting)		
		20% Load	50% Load	100% Load
2	1	1.783	1.821	1.854
	2	1.776	1.811	1.831
	3	1.772	1.798	1.818
	4	1.768	1.781	1.805
3	1	1.805	1.848	1.891
	2	1.793	1.833	1.859
	3	1.787	1.820	1.843
	4	1.781	1.803	1.831
4	1	1.822	1.868	1.918
	2	1.807	1.850	1.883
	3	1.789	1.836	1.866
	4	1.793	1.818	1.850
5	1	1.835	1.884	1.941
	2	1.818	1.863	1.903
	3	1.799	1.849	1.883
	4	1.803	1.823	1.865

NOTE Values are approximate.

Chapter 5 Communication

This section describes the:

- DB-9 communication port
- X-Slot cards
- Remote emergency power-off (REPO)
- Relay output contacts
- Programmable signal inputs
- Parallel communication

Figure 47 shows the location of the communication options and control terminals on the UPS.

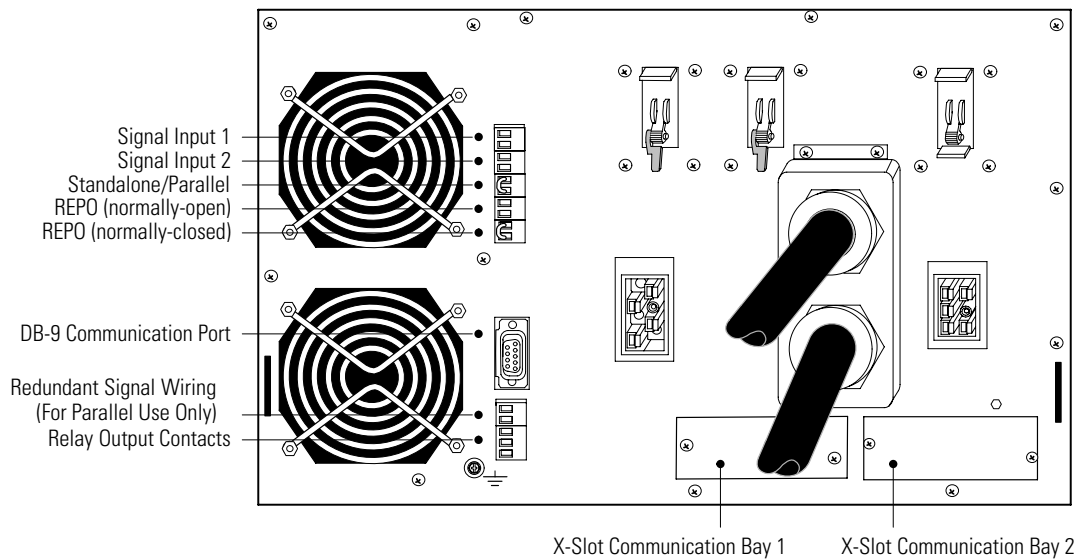

Figure 47. Communication Options and Control Terminals (Standalone UPS shown)

Installing Communication Options and Control Terminals

To install the communication options and control terminals:

1. Install the appropriate X-Slot card and/or necessary cable(s) (see Figure 47 and Figure 48).

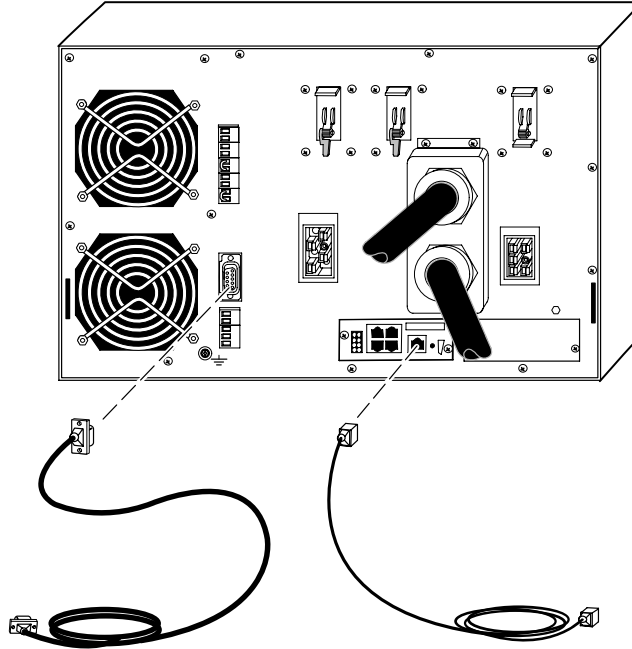

Figure 48. Installing Communication Cables

2. Connect the cables to the appropriate location.
See "Communication Options" on page 91 or "Control Terminals" on page 94 for detailed information.
3. Route and tie the cable(s) out of the way.
4. Continue to "Operation" on page 71 to start up the UPS.

Communication Options

The BladeUPS has serial communication capabilities through the DB-9 communication port or through an X-Slot card in one of the available bays.

The UPS supports two serial communication devices according to the following table:

Independent	Multiplexed	
X-Slot 1	X-Slot 2	DB-9 Communication Port
Any X-Slot card	Any X-Slot card except the Powerware Modem Card	Not in use
Any X-Slot card	Powerware Relay Interface Card Powerware Hot Sync CAN Bridge Card	Available
Any X-Slot card	Not in use	Available



NOTE You can configure relays, signal inputs, and the serial port baud rate through the front panel menus (see Table 4 on page 74).

NOTE In a UPS connected to utility power, X-Slot cards remain powered on even if the input breaker is off.

DB-9 Communication Port

To establish communication between the UPS and a computer, connect your computer to the UPS communication port using the supplied communication cable.

When the communication cable is installed, power management software can exchange data with the UPS. The software polls the UPS for detailed information on the status of the power environment. If a power emergency occurs, the software initiates the saving of all data and an orderly shutdown of the equipment.

The cable pins are identified in Figure 49 and the pin functions are described in Table 6. See Figure 47 on page 89 for the communication port location.

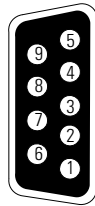

Figure 49. Communication Port

Table 6. Communication Port Pin Assignment

Pin Number	Signal Name	Function	Direction from the UPS
2	TxD	Transmit to external device	Out
3	RxD	Receive from external device	In
5	GND	Signal common (tied to chassis)	—

X-Slot Cards

X-Slot cards allow the UPS to communicate in a variety of networking environments and with different types of devices. The BladeUPS has two available communication bays for any X-Slot card, including:

- **ConnectUPS-X Web/SNMP Card** - has SNMP and HTTP capabilities as well as monitoring through a Web browser interface; connects to a twisted-pair Ethernet (10/100BaseT) network. It has a built-in switching hub that allows three additional network devices to be connected to the network without the requirement of additional network drops. In addition, a Powerware Environmental Monitoring Probe can be attached to obtain humidity, temperature, smoke alarm, and security information.
- **Relay Interface Card** - has isolated dry contact (Form-C) relay outputs for UPS status: Utility failure, Low battery, UPS alarm/OK, or On bypass.
- **Modbus® Card** - allows you to continuously and reliably monitor the UPSs in your Building Management System (BMS).
- **Industrial Relay Card (IRC)** - is used to indicate the operating status of the UPS system using the customer’s monitoring equipment. The IRC uses four isolated normally-open or normally-closed dry relay contacts to indicate the UPS status. Normal, Bypass, Battery, and Alarm mode can be monitored.
- **Modem Card** - provides out-of-band remote notification and monitoring using modem communication directly to cell phones and pagers.

See Figure 47 on page 89 for the location of the two X-Slot communication bays.

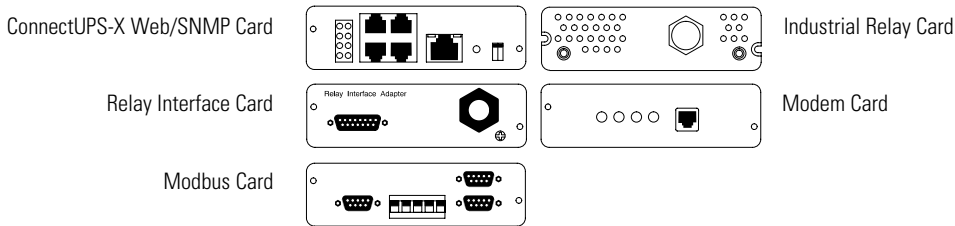

Figure 50. Optional X-Slot Cards

Control Terminals

The cables should be connected to the control terminals with a mating connector. Input and output terminals have a functional isolation from terminal to terminal. They are connected to the UPS chassis through individual 1 MΩ resistors.

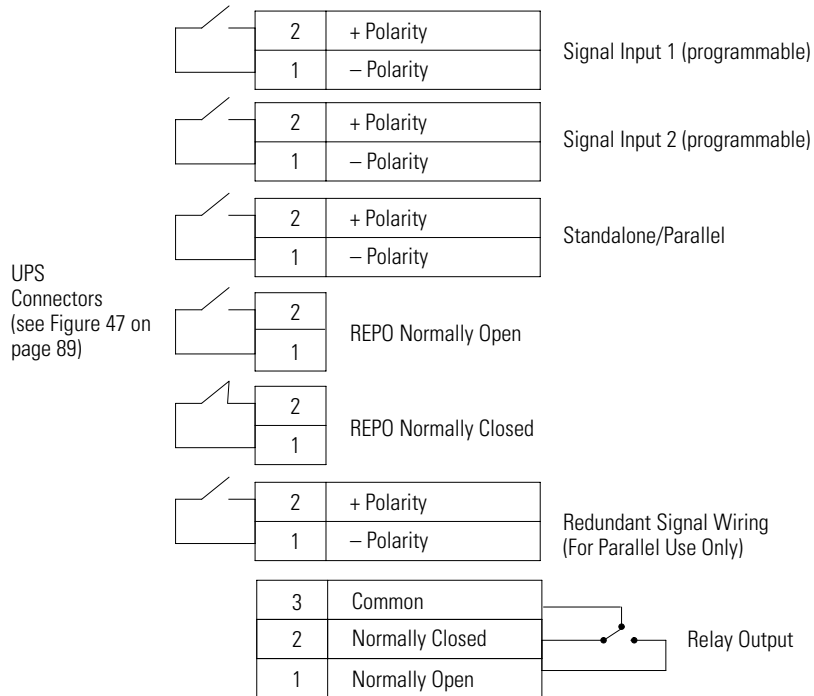

Figure 51. External Control Terminal Connections



NOTE If using a semiconductor switch type, pay attention to the proper polarity. A relay or other mechanical control is preferred.

Remote Emergency Power-off

REPO is used to shut down the UPS from a distance. This feature can be used for shutting down the load and the UPS by thermal relay, for instance in the event of room overtemperature. When REPO is activated, the UPS shuts down all converters, de-energizes all system relays, trips the UPS battery circuit breaker, and fully powers down within 10-15 seconds.

WARNING



The REPO circuit is an IEC 60950 safety extra low voltage (SELV) circuit. This circuit must be separated from any hazardous voltage circuits by reinforced insulation.

CAUTION



- The REPO must not be connected to any utility connected circuits. Reinforced insulation to the utility is required. The REPO switch must have a minimum rating of 24 Vdc and 20 mA and be a dedicated latching-type switch not tied into any other circuit. The REPO signal must remain active for at least 250 ms for proper operation.
- To ensure the UPS stops supplying power to the load during any mode of operation, the input power must be disconnected from the UPS when the emergency power-off function is activated.



NOTE For Europe, the emergency switch requirements are detailed in Harmonized document HD-384-48 S1, "Electrical Installation of the Buildings, Part 4: Protection for Safety, Chapter 46: Isolation and Switching."

REPO Connections		
Wire Function	Terminal Wire Size Rating	Suggested Wire Size
REPO L1	4–0.32 mm ² (12–22 AWG)	0.82 mm ² (18 AWG)
L2		



NOTE Leave the REPO connector installed in the REPO port on the UPS even if the REPO function is not needed.

There are two REPO positions that may be used, normally-open (NO) or normally-closed (NC). See Figure 47 on page 89 for REPO locations.

The pins on the NC REPO connector are connected together. When this connection is open, the logic circuitry completely shuts down the UPS, thus preventing the power from supplying the load. If the use of NC REPO operation is desired, remove the jumper wire and connect a NC external switch. If the use of NO REPO operation is desired, connect a NO external switch.

To install REPO for a parallel system, the selected REPO command (NO or NC) contacts from each UPS in the system must be in parallel. Connect Pin 1 to Pin 1 and connect Pin 2 to Pin 2 of each UPS in parallel for the selected REPO contacts, then connect the appropriate external switch to the selected REPO command.

The REPO wiring of a standalone UPS can be connected with the REPO wiring of a parallel system if the same sense (NO or NC) contacts are used. Be sure to match the polarity for the contacts.



NOTE To restart the UPS, reconnect the REPO connector pins and turn on the UPS manually. The pins must be shorted to keep the UPS running. Maximum resistance is 10 ohm.

NOTE Always test the REPO function before applying your critical load to avoid accidental load loss.

Relay Output Contacts

The UPS incorporates a programmable relay output with potential free contacts for remote alarm indications (see Figure 47 on page 89). An additional four relay outputs can be obtained with the X-Slot compatible Relay Interface Card.

WARNING



The relay output contacts must not be connected to any utility connected circuits. Reinforced insulation to the utility is required. The relay output contacts have a maximum rating of 30 Vac/1A and 60 Vdc/2A nominal values.

Programmable Signal Inputs

The UPS incorporates two programmable signal inputs (see Figure 47 on page 89). Use of non-polar (relay) control input is recommended. The pins must be shorted with maximum resistance of 10 ohm in order to activate the specific input.



NOTE See Figure 51 on page 94 for the polarity and verify these connections if polarity control is required.

Table 7 shows the programmable settings for the signal inputs.

Table 7. Programmable Signal Inputs

Signal	Description
on generator	If active, the High Efficiency setting is disabled (BladeUPS 12i model only) and battery tests are disabled.
charger off	If active, the battery charge function is disabled. In a utility power outage, the discharge of batteries is supported.
on/OFF	If active, the UPS output turns off regardless of the mode of operation. Auxiliary power, communication, and rectifier/battery charger remain functional. Restart is initiated immediately when this signal is inactive.
force bypass	If active, the UPS is forced to static bypass operation regardless of the bypass status.
ext battery breaker	If active, the UPS knows that the external batteries are disconnected.
empty	Not in use (default).

Use the programmable signal inputs to emulate some of the features usually seen on larger three-phase systems. For example:

- Configure the signal from a smoke detector or water leak detector to shut down the system.
- Configure a vibration sensor or air conditioner sensor to shut down the system.
- Set actions for alarms from a generator, such as disabling the charger for an undersized generator or shutdown for a failed generator.
- Configure an ATS (automatic transfer switch) sensor to transfer the system to Bypass mode.

Parallel Communication

The CAN Bridge Card in each paralleled UPS provides connectivity for system metering and operational mode control. Startup, shutdown, and auto-calibration commands given at one UPS also command the other UPSs in the parallel system. The UPSs in a parallel system are in constant communication to monitor settings and status information.

Mode Transfers

If one UPS in a parallel system transfers from High Efficiency operation to Standard operation, the other UPSs transfer also.

When a parallel system is on battery, the front panels display the battery status information of the battery with the lowest runtime remaining. When the first UPS shuts down, the other UPSs also shut down. In a parallel system not fully loaded, the system shifts load to UPSs with the strongest batteries or additional EBMs to maximize runtime.

In a parallel system configured for redundancy, the UPSs use a distributed bypass, and the following alarms cause an individual UPS to shut down instead of transferring to Bypass mode:

- Failure of the fan, fuse, temperature sensor, or power supply
- Inverter AC under voltage
- Battery current limit
- DC link under voltage
- Battery over voltage

Redundant Signal Wiring

BladeUPS 12i model. The redundant signal wiring provides redundant backfeed protection in case of CAN failure in the parallel system. If the CAN fails, the UPSs transfer to Normal mode. The system runs unsynchronized, and any UPS can transfer to Battery mode as necessary. If any UPS must transfer to Bypass mode, the redundant signal wiring allows the entire parallel system to transfer to Bypass mode without backfeeding.

BladeUPS 12 model. The redundant signal wiring provides synchronization protection in case of CAN failure in the parallel system. The system uses the redundant signal wiring to determine the system state when the CAN is down. The system operates the same as with CAN, except for a Check Parallel Board alarm.

Auto-Identification

The BladeUPS parallel system can automatically assign identities to each UPS in the system. To take advantage of this feature, wire the CAN Bridge Cards together as described in "Parallel UPS Installation" on page 50.

Upon startup, the UPS with the initializing jumper installed will identify itself as UNIT 1. The next UPS wired will identify itself as UNIT 2, and so forth. The auto-identification sequence takes about 15-20 seconds to complete once all the UPSs in the parallel system have logic power.

If a UPS is shut down or otherwise loses logic power, the UPS will re-identify itself in the proper sequence once logic power is restored.

If a UPS is shut down and removed from the parallel system, the other UPSs in the system will not re-identify themselves to compensate for the missing UPS until logic power to all the UPSs is cycled. For example, if you remove UNIT 2 and rewire UNIT 3's CAN IN port to UNIT 1's CAN OUT port, UNIT 3 will not re-identify itself as UNIT 2 until logic power is cycled. The CAN Bridge Cards for UNIT 1 and UNIT 3 continue to function normally without the need to re-identify.

Metering

The Output and Load Receptacle meter readings differ between a parallel system and a standalone UPS. In a parallel system, one UPS reads the Load Receptacle value for the total system (the others read zero), but each UPS displays its own Output value.

For example, in a two-unit parallel system with one Anderson load connection for 12 kVA, the Load Receptacle current would read 12 kVA on one UPS and zero on the other UPS, but the Output measurement would be 6 kVA on each UPS (half the total).

In a standalone UPS, the load can be connected from the outlet cord or the Anderson load connector. The Output measurement would be the total load on the UPS, and the Load Receptacle reading would be the portion supplied by the Anderson load connector.

Chapter 6 UPS Maintenance

This section explains how to

- Care for the UPS and batteries
- Replace the UPS batteries and EBMs
- Test new batteries
- Replace the electronics module
- Recycle used batteries or UPS
- Update the UPS firmware

UPS and Battery Care

For the best preventive maintenance, keep the area around the UPS clean and dust-free. If the atmosphere is very dusty, clean the outside of the system with a vacuum cleaner.

For full battery life, keep the UPS at an ambient temperature of 25°C (77°F).



NOTE *The batteries in the UPS are rated for a 3–5 year service life. The length of service life varies, depending on the frequency of usage and ambient temperature. Batteries used beyond expected service life will often have severely reduced runtimes. Replace batteries at least every 5 years to keep units running at peak efficiency.*

Storing the UPS and Batteries

If you store the UPS for a long period, recharge the battery every 6 months by connecting the UPS to utility power. The batteries charge to 80% capacity in less than 5 hours. However, it is recommended that the batteries charge for 48 hours after long-term storage.

Check the battery recharge date on the shipping carton label. If the date has expired and the batteries were never recharged, do not use the UPS. Contact your service representative.

When to Replace Batteries

When the  indicator flashes slowly and the audible alarm beeps intermittently, the batteries may need replacing. Contact your service representative to order new batteries.

Replacing Batteries



NOTE DO NOT DISCONNECT the batteries while the UPS is in Battery mode.

Batteries can be replaced easily without turning the UPS off or disconnecting the load.

If you prefer to remove input power to change the batteries, see “Individual UPS Shutdown” on page 83.

Consider all warnings, cautions, and notes before replacing batteries.

WARNING



- Servicing should be performed by qualified service personnel knowledgeable of batteries and required precautions. Keep unauthorized personnel away from batteries.
 - Batteries can present a risk of electrical shock or burn from high short circuit current. The following precautions should be observed: 1) Remove watches, rings, or other metal objects; 2) Use tools with insulated handles; 3) Do not lay tools or metal parts on top of batteries, 4) Wear rubber gloves and boots.
 - When replacing batteries, replace with the same type and number of batteries or battery packs. Contact your service representative to order new batteries.
 - Proper disposal of batteries is required. Refer to your local codes for disposal requirements.
 - Never dispose of batteries in a fire. Batteries may explode when exposed to flame.
 - Do not open or mutilate the battery or batteries. Released electrolyte is harmful to the skin and eyes and may be extremely toxic.
 - Determine if the battery is inadvertently grounded. If inadvertently grounded, remove source from ground. Contact with any part of a grounded battery can result in electrical shock. The likelihood of such shock can be reduced if such grounds are removed during installation and maintenance (applicable to equipment and remote battery supplies not having a grounded supply circuit).
 - ELECTRIC ENERGY HAZARD. Do not attempt to alter any battery wiring or connectors. Attempting to alter wiring can cause injury.
 - Disconnect charging source prior to connecting or disconnecting battery terminals.
-

How to Replace EBMs



CAUTION

The EBM is heavy (see page 114). A minimum of two people are required to lift the cabinet into the rack.

To replace the EBMs:

1. Switch all battery circuit breakers to the OFF (O) position (see Figure 29 on page 45).
2. Unplug the EBM cable from the UPS.

If additional EBMs are installed, unplug the EBM cable from the battery connector on each EBM.
3. If not already installed, install the supplied mounting brackets on the new EBM.
4. Replace the EBM. See “Recycling the Used Battery or UPS” on page 112 for proper disposal.
5. Plug the new EBM into the UPS as shown in Figure 29 on page 45.

For additional EBMs, plug the EBM cable into the battery connector on the adjacent EBM.
6. Remove the breaker tie from the circuit breaker on all EBMs.
7. Switch all battery circuit breakers to the ON (I) position.

How to Replace UPS Internal Batteries



CAUTION

The UPS internal batteries are heavy (see page 114). Each battery tray holds two rows of five batteries. Use caution when handling the heavy battery trays.

To replace the battery trays in the UPS cabinet:

1. Verify that the battery circuit breaker is in the OFF (O) position (see Figure 32 on page 49).
2. Remove the UPS front cover and set it aside (see Figure 52):

Grasp the fingergrrips on both sides of the cover and pull the cover forward firmly. Unplug the LCD cable connecting the back of the control panel to the electronics module.

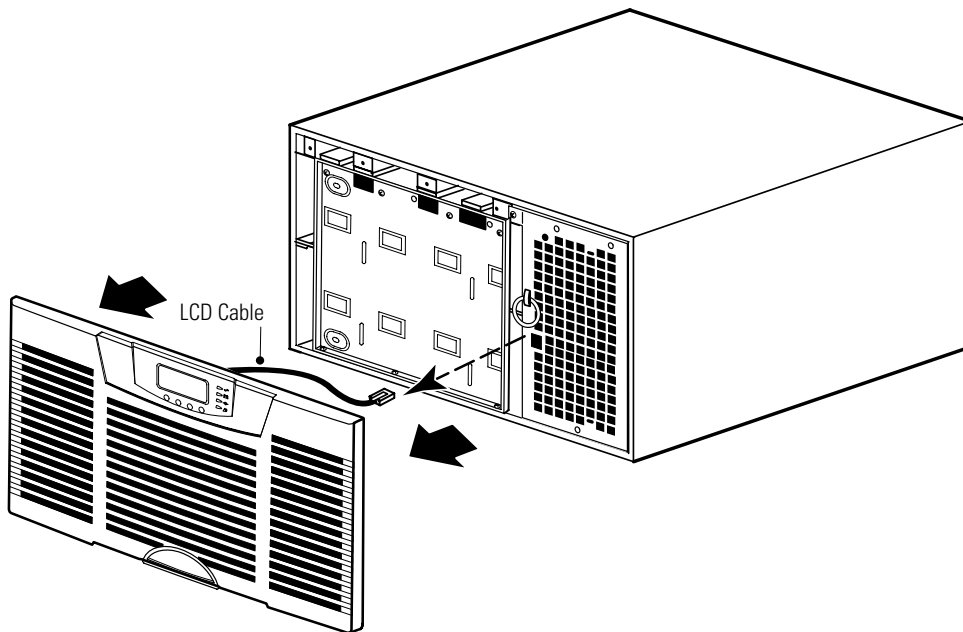

Figure 52. Removing the UPS Front Cover



NOTE Disconnecting the control panel from the electronics module automatically transfers the UPS to Bypass mode.

3. Remove the eight screws on the battery cover plate and retain. Remove the plate. See Figure 53.

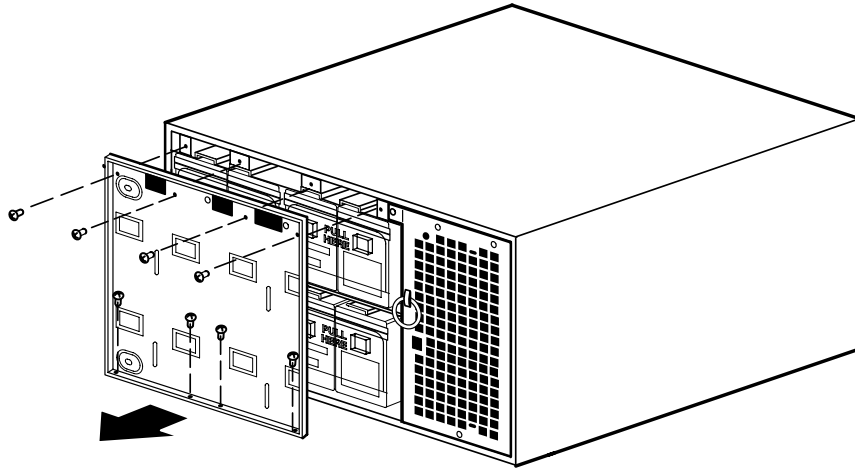

Figure 53. Removing the UPS Battery Cover Plate



CAUTION

- The UPS internal batteries are heavy (see page 114). Each battery tray holds two rows of five batteries. Use caution when handling the heavy battery trays.
- Pull the battery trays out onto a flat, stable surface. The battery trays are unsupported when you pull them out of the UPS.

4. Untuck the plastic handle at the end of a battery tray. Pull the handle firmly to remove the tray. Use both hands to support the tray as it leaves the UPS cabinet.

Repeat for each battery tray. See “Recycling the Used Battery or UPS” on page 112 for proper disposal.

5. Slide the new battery trays into the cabinet (see Figure 54). Verify each tray is properly aligned before sliding the tray in.

When a tray is fully installed, tuck the plastic handle on the end of the tray into place.

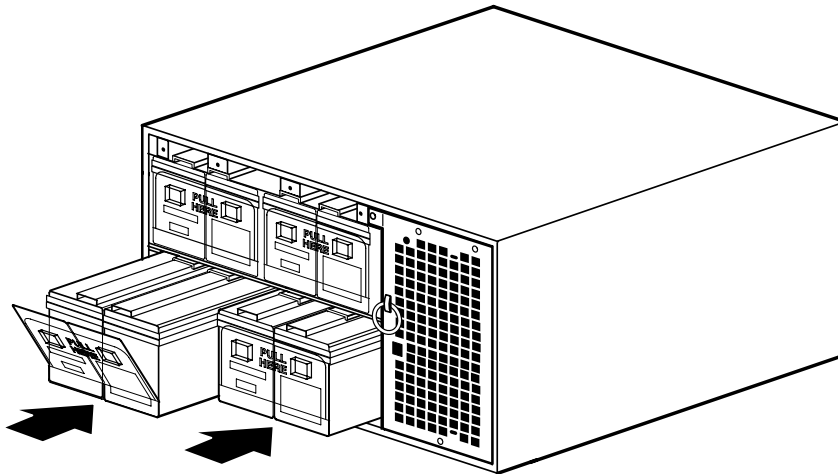

Figure 54. Installing the UPS Battery Trays

6. Reinstall the battery cover plate.
7. Replace the UPS front cover (see Figure 55):

Plug the LCD cable from the control panel on the front cover into the connector on the electronics module. Use care to gently loop the LCD cable in front of the electronics module.

Push the top of the front cover firmly into place, and then push the bottom firmly into place.



NOTE Reconnecting the control panel to the electronics module automatically transfers the UPS to Normal mode.

8. Verify that there are no alarms indicated on the control panel.

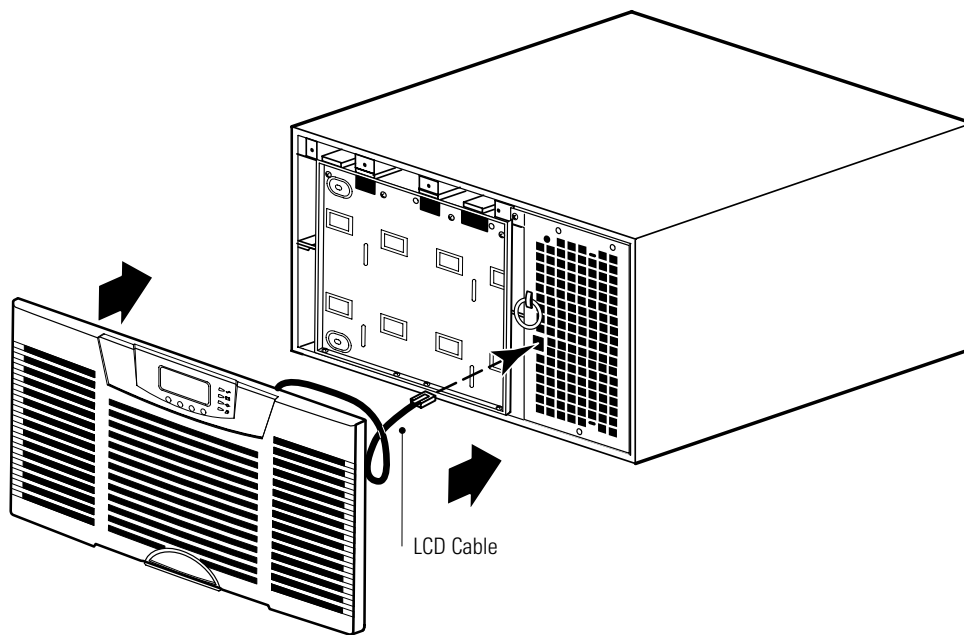

Figure 55. Replacing the UPS Front Cover

Testing New Batteries



NOTE *The batteries must be fully charged and the UPS must not be in Battery mode to perform the battery test.*

NOTE *For an accurate battery test, test the UPS with at least 10% load applied to the UPS.*

To test new batteries:

1. Plug the UPS into a power outlet for 48 hours to charge the battery.
2. Press any button to activate the menu options.
3. Select CONTROL then START BATTERY TEST.

During the battery test, the front panel displays “Battery Test Pending.”

A failed battery test initiates a Battery Test Failed alarm.

To cancel a battery test in progress:

1. Press any button to activate the menu options.
2. Select CONTROL, START BATTERY TEST, then CANCEL.

Replacing the Electronics Module

The electronics module can be replaced easily without turning the UPS off or disconnecting the load. Battery mode is not available and your equipment is not protected; however, the utility power continues to be passively filtered by the UPS.

If you prefer to remove input power to change the electronics module, see “Individual UPS Shutdown” on page 83.



NOTE *DO NOT DISCONNECT the electronics module while the UPS is in Battery mode.*

To replace the electronics module:

- 1. Standalone UPS configurations only.** Transfer the UPS to Bypass mode.

Parallel for capacity configurations only. Transfer the UPS to Bypass mode. The CAN bus remains energized.

Parallel for redundancy configurations only. No mode transfer is necessary. If the UPS is operating in a parallel for redundancy configuration when its electronics module is removed, the load automatically transfers to the remaining UPSs. The CAN bus remains energized.



NOTE *Disconnecting the control panel from the electronics module automatically transfers the UPS to Bypass mode. However, transferring the UPS to Bypass mode manually BEFORE disconnecting the control panel provides extra protection to the electronics module and is recommended.*

- 2. Parallel configurations only.** Disconnect the redundant signal cable(s) from the UPS. For the location of the redundant signal cable, see Figure 36 on page 53.

3. Remove the UPS front cover and the electronics module and set them aside (see Figure 56):

To remove the UPS front cover, grasp the fingergrrips on both sides of the cover and pull the cover forward firmly. Unplug the LCD cable connecting the back of the control panel to the electronics module.

To remove the electronics module, remove the electronics module locking screw at the top left of the electronics module and retain. Grasp the ring handle at the middle of the module and pull the module slowly out of the cabinet. Pull firmly to unseat the connectors. Use two hands to support the module.



NOTE Treat the electronics module with care to avoid damaging the fans, connectors, or internal circuitry.

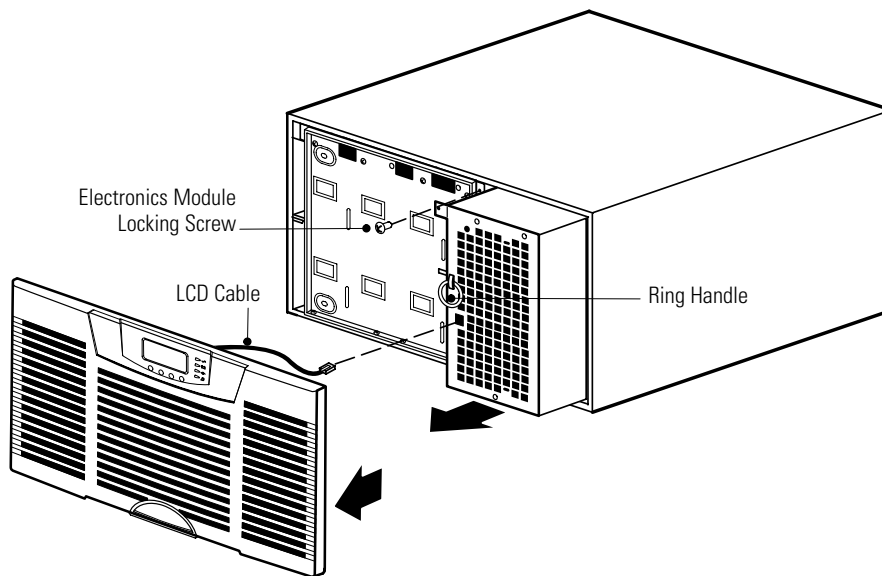

Figure 56. Removing the UPS Front Cover and Electronics Module

4. Label the original module with masking tape or some other identifier. Record the serial number of the replacement module for your warranty.

If not returning the electronics module for warranty, see the following section, "Recycling the Used Battery or UPS," for proper disposal.

5. Insert the replacement module by sliding it carefully into the cabinet. Verify that it seats firmly against the rear of the cabinet.

Reinstall the electronics module locking screw.

6. **Parallel configurations only.** Reconnect the redundant signal cable(s).
7. Replace the UPS front cover (see Figure 57):

Plug the LCD cable from the control panel on the front cover into the connector on the electronics module. Use care to gently loop the LCD cable in front of the electronics module.

Push the top of the front cover firmly into place, and then push the bottom firmly into place.

8. Verify that there are no alarms indicated on the control panel.
9. Transfer the UPS to Normal mode.

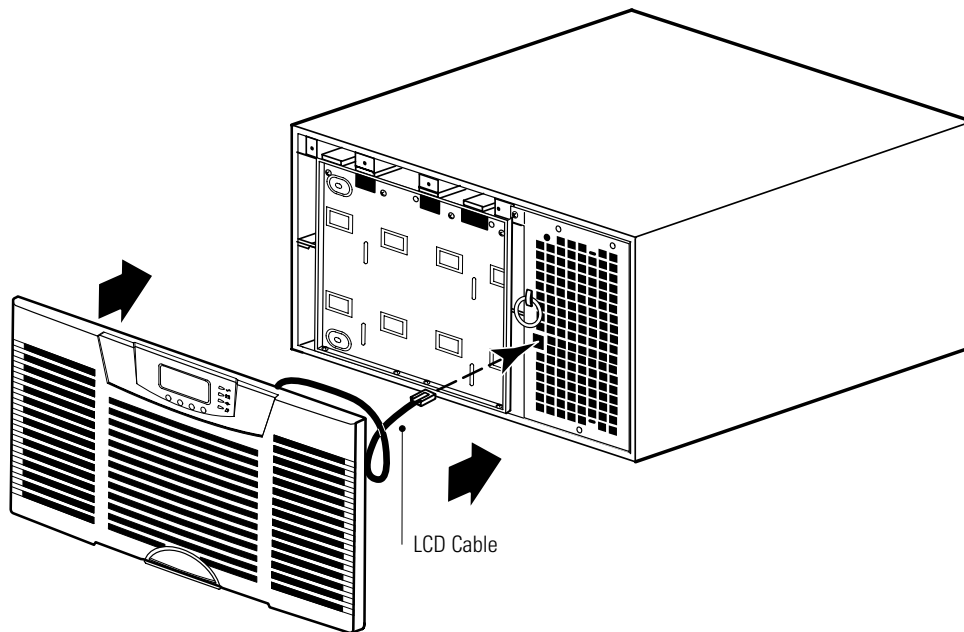

Figure 57. Replacing the UPS Front Cover

Recycling the Used Battery or UPS

Contact your local recycling or hazardous waste center for information on proper disposal of the used battery or UPS.



WARNING

- Do not dispose of the battery or batteries in a fire. Batteries may explode. Proper disposal of batteries is required. Refer to your local codes for disposal requirements.
- Do not open or mutilate the battery or batteries. Released electrolyte is harmful to the skin and eyes. It may be toxic.



CAUTION

Do not discard the UPS or the UPS batteries in the trash. This product contains sealed, lead-acid batteries and must be disposed of properly. For more information, contact your local recycling/reuse or hazardous waste center.



CAUTION

Do not discard waste electrical or electronic equipment (WEEE) in the trash. For proper disposal, contact your local recycling/reuse or hazardous waste center.

Updating the UPS Firmware

To keep the UPS firmware updated with the latest improvements and benefits, visit www.powerware.com often for updates. You can download the latest firmware version and the instructions for installing it.



NOTE When adding a new UPS to a parallel system or updating one UPS's firmware, verify that all UPSs in the parallel system are updated to the same firmware version.

Chapter 7 Specifications

This section provides the following specifications:

- Model list
- Weights and dimensions
- Electrical input and output
- Environmental and safety
- Battery

Table 8. Model List

UPS Model Number	Power Levels (Rated at Nominal Inputs)
BladeUPS 12	12 kVA or 12 kW at 208V*
BladeUPS 12i	12 kVA or 12 kW at 400V*
EBM Model Number	
BladeEBM	
BladeUPS Bar Model Number	
BladeUPS Bar 60	For up to 6 UPSs

* Derated for line cord and nominal line voltage

Cord Model Number	Description	Input Plug Type	Length
UPSCord12UL	12 kW UL input	IEC 309-60A	3.7m (12 ft)
UPSCord12ULR	12 kW UL input/output	IEC 309-60A	1.8/1.2m (6/4 ft)
UPSCordPUL	12 kW UL parallel	Anderson	0.5m (1.5 ft)
UPSCord12CE	12 kW CE input	IEC 309-32A	3.7m (12 ft)
UPSCord12CER	12 kW CE input/output	IEC 309-32A	1.8/1.2m (6/4 ft)
UPSCord12PCE	12 kW CE parallel	Anderson	0.5m (1.5 ft)

Table 9. Weights and Dimensions

	UPS	Extended Battery Module (EBM)
Dimensions (WxDxH)	441 x 660 x 261 mm 17.4" x 26" x 10.3" (6U)	438 x 660 x 131 mm 17.2" x 26.0" x 5.2" (3U)
Weights	UPS without internal batteries: 61 kg (135 lb) UPS with internal batteries: 140 kg (307 lb) Individual battery: 2 kg (4.4 lb) Each battery tray: 20 kg (44 lb) Electronics module: 19.5 kg (43 lb)	77 kg (170 lb)

Table 10. BladeUPS Bar 60

Dimensions (WxDxH)	140 x 113 x 1827 mm (5.5" x 4.4" x 71.9")
Weight	BladeUPS Bar: 19 kg (42 lb); Wireway Enclosure: 20 kg (45 lb) Total Weight: 39 kg (87 lb)
UPS Connections	Up to 6
Rack Placement	Bottom wireway fits into the bottom 6U of standard rack space. Top wireway fits into the top 6U of standard rack space.

Table 11. BladeUPS Rack

Dimensions (WxDxH)	610 x 1067 x 2032 mm (24" x 42" x 80")
Weight	Rack without side panels or casters: 99 kg (219 lb); Side panels (each): 8.5 kg (19 lb); Casters (4): 5 kg (10 lb) Total Weight: 121 kg (267 lb)

Table 12. Electrical Input

	BladeUPS 12	BladeUPS 12i
Nominal Voltage	120/208V three-phase	230/400V three-phase
Nominal Frequency	50/60 Hz	50/60 Hz
Frequency Range	45–65 Hz	45–65 Hz
Default Frequency	Auto-detected	Auto-detected
Rated Input Current	36A	24A
Connections	IEC 309-60A power cord IEC 309-32A power cord For paralleling, a single Anderson input/output cord connects to the BladeUPS Bar (see Table 8 on page 113).	
Noise Filtering	MOVs and common mode line filter	
Input Power Factor	High Efficiency setting: load dependent Standard setting: >0.99	
Input Mode	Three-phase	

Table 13. Electrical Output

	BladeUPS 12	BladeUPS 12i
Nominal Output Voltage	120/208 Vac three-phase	230/400 Vac three-phase
Output Voltage Variation (Standard)	104–132 Vac phase to neutral, 180–229 Vac phase to phase	207–253 Vac phase to neutral, 358–438 Vac phase to phase
Output Voltage Variation (Reduced)	108–132 Vac phase to neutral, 187–229 Vac phase to phase	Not applicable
Output Receptacles	Anderson connector	Anderson connector
Short Circuit Capability (Battery Mode)	84A, <300 ms	44A, <300 ms
Short Circuit Capability (Normal Mode)	Limited by 50A input breaker	Limited by 30A input breaker
Nominal Output Frequency	50–60 Hz auto-detection (Normal mode) 50 or 60 Hz (Battery mode)	
Output Frequency Variation	Synchronized (Normal mode) ±0.1 when not synchronized with source (Battery mode)	
Output Overload	100–110%: load transfers to Bypass mode after 10 minutes 110–125%: load transfers to Bypass mode after 1 minute 125–150%: load transfers to Bypass mode after 5 seconds >150%: load transfers to Bypass mode after 300 ms	
Voltage Waveform	Normal mode and Battery mode: Sine wave; <2% THD with linear load; <5% with nonlinear load	
Full Output	Three-phase	

Table 14. Environmental and Safety

	BladeUPS 12	BladeUPS 12i
Surge Suppression	ANSI C62.41 Category B3	EN 61000-4-6
Safety Conformance	UL 1778 4 th edition; CSA C22.2, No. 107.3	EN and IEC 62040-1-1
Agency Markings	cULus, ICES, VCCI	GS, CE
EMC (Class A)	FCC Part 15	EN 62040-2
Operating Temperature	0°C to 40°C (32°F to 104°F) Optimal battery performance: 5°C to 25°C (41°F to 77°F)	
Storage Temperature	0°C to 25°C (32°F to 77°F)	
Transit Temperature	-25°C to 55°C (-13°F to 131°F)	
Relative Humidity	Operating: 5–95% noncondensing Non-operating: 5–95% relative humidity, 38.7°C (101.7°F) Maximum wet bulb temperature with no cosmetic damage	
Operating Altitude	Up to 1,000 meters (3,300 ft) above sea level; up to 2,000 meters (6,600 ft) with 1% derating per +100 meters (330 ft)	
Transit Altitude	Up to 15,000 meters (49,000 ft) above sea level	
Heat Dissipation	1432 BTU/hr maximum at 100% rated load (High Efficiency mode) 4094 BTU/hr maximum at 100% rated load (Standard mode)	
Audible Noise	Less than 58 dBA at 1 meter typical (Normal mode) Less than 64 dBA at 1 meter typical (Battery mode)	
Leakage Current	<3.5 mA	
Communication	DB-9: 1200–19200 baud	

Table 15. Battery

	UPS Internal Batteries	+1 EBM	+2 EBMs	+3 EBMs	+4 EBMs
Configuration	(40) 12V, 5 Ah	(20) 12V, 9 Ah	(40) 12V, 9 Ah	(60) 12V, 9 Ah	(80) 12V, 9 Ah
Type	Sealed, maintenance-free, valve-regulated, lead-acid				
Monitoring	Advanced monitoring for earlier failure detection and warning				
Charging (in minutes)	8–10 times the discharge time				

NOTE Charging times are approximate and are to 80% usable capacity at nominal line voltage after full load discharge.

Table 16. Battery Runtimes (in Minutes)

Model	UPS Internal Batteries	+1 EBM	+2 EBMs	+3 EBMs	+4 EBMs
BladeUPS 12	4.8	12	20	27	34
BladeUPS 12i	4.8	12	20	27	34

NOTE Battery times are approximate and vary depending on the load configuration and battery charge.

Chapter 8 Troubleshooting



The BladeUPS is designed for durable, automatic operation and also alerts you whenever potential operating problems may occur. Usually the alarms shown by the control panel do not mean that the output power is affected. Instead, they are preventive alarms intended to alert the user. Use the following troubleshooting chart to determine the UPS alarm condition.







Typical Alarms and Conditions

The following table describes typical alarms and conditions. If an alarm appears with a service code, contact the Help Desk (see page 123).

To check the Event Log for a list of active alarms:

1. Press any button on the front panel display to activate the menu options.
2. Press the ↓ button until EVENT LOG displays.
3. Press the → button to display the list of alarms and conditions.

Alarm or Condition	Possible Cause	Action
<p>On Battery</p>  <p>LED is on. 1 short beep every 5 seconds.</p>	<p>A utility failure has occurred and the UPS is in Battery mode.</p>	<p>The UPS is powering the equipment with battery power. Prepare your equipment for shutdown.</p>
<p>Battery Low</p>  <p>LED is on. Continuous beep for 10 seconds.</p>	<p>The UPS is in Battery mode and the battery is running low.</p>	<p>This warning is approximate, and the actual time to shutdown may vary significantly. Depending on the UPS load and number of Extended Battery Modules (EBMs), the Battery Low warning may occur before the batteries reach 25% capacity. See Table 16 on page 118 for estimated runtimes and “Setting the Battery Low Alarm Level” on page 88 for configuration information.</p> <p>When utility power is restored, the UPS restarts automatically, provides power to the load, and charges the battery.</p>

Alarm or Condition	Possible Cause	Action
Battery Breaker  LED is on. 1 beep every 3 seconds.	The UPS does not recognize the internal batteries.	Verify the UPS battery circuit breaker is in the ON (I) position. If the condition persists, contact your service representative.
On Bypass  LED is on. 1 beep every 3 seconds.	The UPS is in Bypass mode.	The equipment transferred to bypass utility power. Battery mode is not available and your equipment is not protected; however, the utility power continues to be passively filtered by the UPS. Check for one of the following alarms: overtemperature, overload, UPS failure, hot swap, or remote emergency power-off (REPO).
Bypass Unavailable  LED is flashing slowly. 1 beep every second.	Bypass is not available because the UPS may be receiving bypass utility power that may be unstable or in brownout conditions.	Check the bypass utility. The UPS continues to supply power to your equipment. Check for one of the following alarms: bypass over or under voltage, bypass over or under frequency, or bypass unavailable.
Battery Connection  LED is on. 1 beep every 3 seconds.	The UPS does not recognize the internal batteries. Two or more battery trays are disconnected.	If the condition persists, contact your service representative. Verify that all battery trays are fully seated and locked in place. If the condition persists, contact your service representative.
Overload  LED is on. 1 beep every 3 seconds.	Power requirements exceed the UPS capacity (greater than 100% of nominal; see page 116 for specific output overload ranges).	Remove some of the equipment from the UPS. The UPS continues to operate, but may switch to Bypass mode if the load increases. The alarm resets when the condition becomes inactive.
Overtemperature  LED is on. 1 beep every 3 seconds.	The UPS internal temperature is too high or a fan has failed.	Shut down the UPS. Clear vents and remove any heat sources. Allow the UPS to cool. Ensure the airflow around the UPS is not restricted. Restart the UPS. If the condition persists, contact your service representative.
Site Wiring Fault  LED is on. 1 beep every 3 seconds.	Ground wire connection does not exist, or the line and neutral wires are reversed in the wall outlet.	Have a qualified electrician correct the wiring.

Alarm or Condition	Possible Cause	Action
The UPS does not provide the expected backup time.	The batteries need charging or service.	Apply utility power for 48 hours to charge the batteries. If the condition persists, contact your service representative.
	Battery circuit breakers are in the OFF (O) position.	Switch all battery circuit breakers to the ON (I) position.
Power is not available at the UPS output receptacle.	The UPS is in Standby mode.	Supply power to the connected equipment: Press any button to display the menu options. Select TURN UPS ON/OFF, TURN UPS ON, and OK to confirm. Press and hold OK for 3 seconds, until the UPS stops beeping.
	The REPO switch is active or the REPO connector is missing.	Reset the REPO switch and restart the UPS. Verify that the REPO connector is present.
The UPS does not start.	The main utility breaker is off.	Verify that the main utility breaker is on.
	The power cord is not connected correctly.	Have a licensed electrician check the power cord connections.
	The batteries or electronics module is being replaced.	Complete the replacement procedure before starting the UPS.
	The REPO switch is active or the REPO connector is missing.	Reset the REPO switch and restart the UPS. Verify that the REPO connector is present.
The UPS does not turn off.	The batteries or electronics module is being replaced.	Complete the replacement procedure before shutting down the UPS.
The UPS operates normally, but some or all of the protected equipment is not on.	The equipment is not connected to the UPS correctly.	Verify that the equipment is plugged into the UPS receptacles.
	Output circuit breaker is in the OFF (O) position.	Switch output circuit breaker to the ON (I) position.
Battery test pending.	A battery test is in progress.	Wait until the battery test completes. To cancel a test in progress, see "Testing New Batteries" on page 108.
Battery test failed.	The batteries need service.	Contact your service representative.
Battery test did not run.	The bypass utility was not present or was not within limits.	Verify that the bypass utility is available and within limits.
	Batteries were not fully charged.	Apply utility power for 48 hours to charge the batteries, then restart the battery test.
	User cancelled the battery test through the front panel.	Restart the battery test.

Alarm or Condition	Possible Cause	Action
Battery test aborted.	The bypass utility became unavailable during the test.	Verify that the bypass utility is available and within limits. Restart the battery test. If the battery test aborts repeatedly, see "Running Automatic Battery Tests" on page 87.
	User cancelled the battery test through the front panel.	Restart the battery test.
The UPS does not transfer to Bypass mode.	The bypass utility does not qualify.	Check the bypass utility. The UPS is receiving bypass utility power that may be unstable or in brownout conditions.
	Bypass mode is disabled.	Check that the Usage of Bypass user setting is Enabled (see page 74).
Check Parallel Board	The UPS is not recognizing another paralleled UPS.	From the UPS Status menu, select the Units on CAN Bus option and verify that all UPSs appear in the list. If any UPS is missing, verify the Powerware Hot Sync CAN Bridge Card connections and recheck the status from the UPS front panel. If all UPSs appear in the list, check the redundant signal wiring (see page 54). Set the system to internal Bypass mode (see page 101). If the condition persists, contact your service representative.
Abnormal output voltage at startup	The system is not configured as parallel.	Verify the CAN wiring (see page 52). Verify the line cord is installed properly. Shut down the UPS where the alarm is indicated. Start up the UPS. Select the Turn System On option through the front panel of the UPS that was turned off.
Selective Trip	The Powerware Hot Sync CAN Bridge Card is not wired correctly.	Verify the CAN wiring (see page 52). Verify the redundant signal wiring (see page 54). If the condition persists, contact your service representative.
Redundancy Loss Due to Overload	The specified power rating of the parallel system has been exceeded.	The load is supported, but the system lacks redundant protection while the overload persists. Remove some of the protected equipment.
Configuration Error and the UPS does not start.	The UPS failed to identify itself as a paralleled UPS within two minutes after utility power was applied.	Verify the CAN wiring (see page 52). If the condition persists, contact your service representative.

Silencing the Alarm

Before silencing an alarm, check the alarm condition and perform the applicable action to resolve the condition.

Press any button on the front panel display to silence the alarm. If the alarm status changes, the alarm beeps again, overriding the previous alarm silencing.

Service and Support

If you have any questions or problems with the UPS, call your **Local Distributor** or the **Help Desk** at one of the following telephone numbers and ask for a UPS technical representative.

United States: **1-800-843-9433** or **1-919-870-3028**
Canada: **1-800-461-9166 ext 260**
All other countries: **Call your local service representative**

Please have the following information ready when you call for service:

- Model number
- Serial number
- Firmware version number
- Date of failure or problem
- Symptoms of failure or problem
- Customer return address and contact information

If repair is required, you will be given a Returned Material Authorization (RMA) Number. This number must appear on the outside of the package and on the Bill Of Lading (if applicable). Use the original packaging or request packaging from the Help Desk or distributor. Units damaged in shipment as a result of improper packaging are not covered under warranty. A replacement or repair unit will be shipped, freight prepaid for all warrantied units.



NOTE For critical applications, immediate replacement may be available. Call the **Help Desk** for the dealer or distributor nearest you.

Chapter 9 Warranty

One-Year Limited Warranty (Global)

Powerware UPS Model: BladeUPS

WARRANTOR: The warrantor for the limited warranties set forth herein is Eaton Electrical Inc., a Delaware Corporation company ("Company").

LIMITED WARRANTY: This limited warranty (this "Warranty") applies only to the original End-User (the "End-User") of any BladeUPS Products (individually and collectively, the "Product") purchased and registered with Eaton and cannot be transferred. This Warranty applies even in the event that the Product is initially sold by Company for resale to an End-User.

LIMITED WARRANTY PERIOD: The period covered by this Warranty for Product is twelve (12) months from the date of purchase or eighteen (18) months from date of Product shipment, whichever occurs first.

WHAT THIS LIMITED WARRANTY COVERS: The warrantor warrants that the Product and battery (individually and collectively, the "Warranted Items") are free from defects in material and workmanship. If, in the opinion of Company, a Warranted Item is defective and the defect is within the terms of this Warranty, Company's sole obligation will be to repair or replace such defective Warranted Item (including by providing service, parts and labor, as applicable), at the option of Company.

PROCEDURES FOR REPAIR OR REPLACEMENT OF WARRANTED ITEMS: The Warranted Item will be repaired or replaced at a Company site or such other location as determined by Company.

If the Warranted Item is to be replaced by Company, and the End-User supplies a credit card number or purchase order for the value of the replacement Product, Company will use commercially reasonable business efforts to ship (via standard ground shipment and at no cost to the End-User) the replacement Warranted Item to the End-User within one (1) business day after Company receives notice of the warranty claim. In such case, the End-User must return (at Company's expense) the defective Warranted Item to Company in the same packaging as the replacement Warranted Item received by the End-User or as otherwise instructed by Company. If Company does not receive the defective Warranted Item, Company will either charge the End-User's credit card, or send the End-User an invoice (which the End-User agrees to pay), for the value of the replacement Product.

If the Warranted Item is to be replaced by Company, but the End-User is unwilling or unable to supply a credit card number or purchase order for the value of the replacement Product, Company will use commercially reasonable business efforts to ship (via standard ground shipment and at no cost to the End-User) the replacement Warranted Item to the End-User within one (1) business day after Company receives the defective Product from the End-User.

In any case, Company will provide shipping instructions and will pay its designated carrier for all shipping charges for return of defective equipment and replacement of Warranted Items. Any returned Warranted Item or parts that are replaced may be new or reconditioned. All Warranted Items returned to Company and all parts replaced by Company shall become the property of Company.

WHAT THIS LIMITED WARRANTY DOES NOT COVER: This Warranty does not cover any defects or damages caused by: (a) failure to properly store the Product before installation, including the charge of batteries no later than the date indicated on the packaging; (b) shipping and delivery of the Product if shipping is FOB Factory; (c) damage caused by fire, flood, lightning, vandalism, acts of God, Customer's neglect, misuse, misapplication, incorrect connection or external damage; or that has been subject to repair or alteration by Customer (or a third party) not authorized by Company in writing; (d) repair or alteration not authorized in writing by Company personnel or performed by an authorized Company Customer Service Engineer or Agent; (e) improper testing, operation, maintenance, adjustment, or modification of any kind not authorized in writing by Company personnel or performed by an authorized Company Customer Service Engineer or Agent; or (f) use of the Product under other than normal operating conditions or in a manner inconsistent with the Product's labels or instructions.

This Warranty is not valid if the Product's serial numbers have been removed or are illegible. Any Warranted Items repaired or replaced pursuant to this Warranty will be warranted for the remaining portion of the original Warranty subject to all the terms thereof.

Company shall not be responsible for any charges for testing, checking, removal or installation of Warranted Items.

COMPANY DOES NOT WARRANT EQUIPMENT NOT MANUFACTURED BY COMPANY. IF PERMITTED BY THE APPLICABLE MANUFACTURER, COMPANY SHALL PASS THROUGH SUCH MANUFACTURER'S WARRANTIES TO END-USER.

COMPANY DOES NOT WARRANT SOFTWARE, INCLUDING SOFTWARE EMBEDDED IN PRODUCTS, THAT IS NOT CREATED BY COMPANY. WITHOUT LIMITING THE FOREGOING, COMPANY SPECIFICALLY DOES NOT WARRANT SOFTWARE (SUCH AS LINUX) THAT WAS CREATED USING AN "OPEN SOURCE" MODEL OR IS DISTRIBUTED PURSUANT TO AN OPEN SOURCE LICENSE.

THIS WARRANTY IS THE SOLE AND EXCLUSIVE WARRANTY OFFERED BY COMPANY WITH RESPECT TO THE PRODUCTS AND SERVICES AND, EXCEPT FOR SUCH FOREGOING WARRANTY COMPANY DISCLAIMS ALL OTHER WARRANTIES INCLUDING BUT NOT LIMITED TO ANY IMPLIED WARRANTIES OF MERCHANTABILITY, TITLE, NON-INFRINGEMENT, AND FITNESS FOR A PARTICULAR PURPOSE. CORRECTION OF NON-CONFORMITIES IN THE MANNER AND FOR THE PERIOD OF TIME PROVIDED ABOVE SHALL CONSTITUTE COMPANY'S SOLE LIABILITY AND END-USER'S EXCLUSIVE REMEDY FOR FAILURE OF COMPANY TO MEET ITS WARRANTY OBLIGATIONS, WHETHER CLAIMS OF THE END-USER ARE BASED IN CONTRACT, IN TORT (INCLUDING NEGLIGENCE OR STRICT LIABILITY), OR OTHERWISE.

LIMITATION OF LIABILITY: The remedies of the End-User set forth herein are exclusive and are the sole remedies for any failure of Company to comply with its obligations hereunder. In no event shall Company be liable in contract, in tort (including negligence or strict liability) or otherwise for damage to property or equipment other than the Products, including loss of profits or revenue, loss of use of Products, loss of data, cost of capital, claims of customers of the End-User or any special, indirect, incidental or consequential damages whatsoever. The total cumulative liability of Company hereunder whether the claims are based in contract (including indemnity), in tort (including negligence or strict liability) or otherwise, shall not exceed the price of the Product on which such liability is based.

Company shall not be responsible for failure to provide service or parts due to causes beyond Company's reasonable control.

END-USER'S OBLIGATIONS: In order to receive the benefits of this Warranty, the End-User must register the product warranty (via mail or online at www.powerware.com "warranty registration"); use the Product in a normal way; follow the Product's user's guide; and protect against further damage to the Product if there is a covered defect.

OTHER LIMITATIONS: Company's obligations under this Warranty are expressly conditioned upon receipt by Company of all payments due to it (including interest charges, if any). During such time as Company has not received payment of any amount due to it for the Product, in accordance with the contract terms under which the Product is sold, Company shall have no obligation under this Warranty. Also during such time, the period of this Warranty shall continue to run and the expiration of this Warranty shall not be extended upon payment of any overdue or unpaid amounts.

COSTS NOT RELATED TO WARRANTY: The End-User shall be invoiced for, and shall pay for, all services not expressly provided for by the terms of this Warranty, including without limitation, site calls involving an inspection that determines no corrective maintenance is required. Any costs for replacement equipment, installation, materials, freight charges, travel expenses or labor of Company representatives outside the terms of this Warranty will be borne by the End-User.

OBTAINING WARRANTY SERVICE: In the USA, call the Customer Reliability Center 7x24 at 800-356-5737. Outside of the USA, contact your local Powerware product sales or service representative, or call the Customer Reliability Center in the USA at 919-870-3149. For comments or questions about this Warranty, write to the Customer Quality Representative, 3301 Spring Forest Road, Raleigh, North Carolina 27616 USA.



164201649 3